

Forged Steel Floating Ball Valves Model T3 & B3

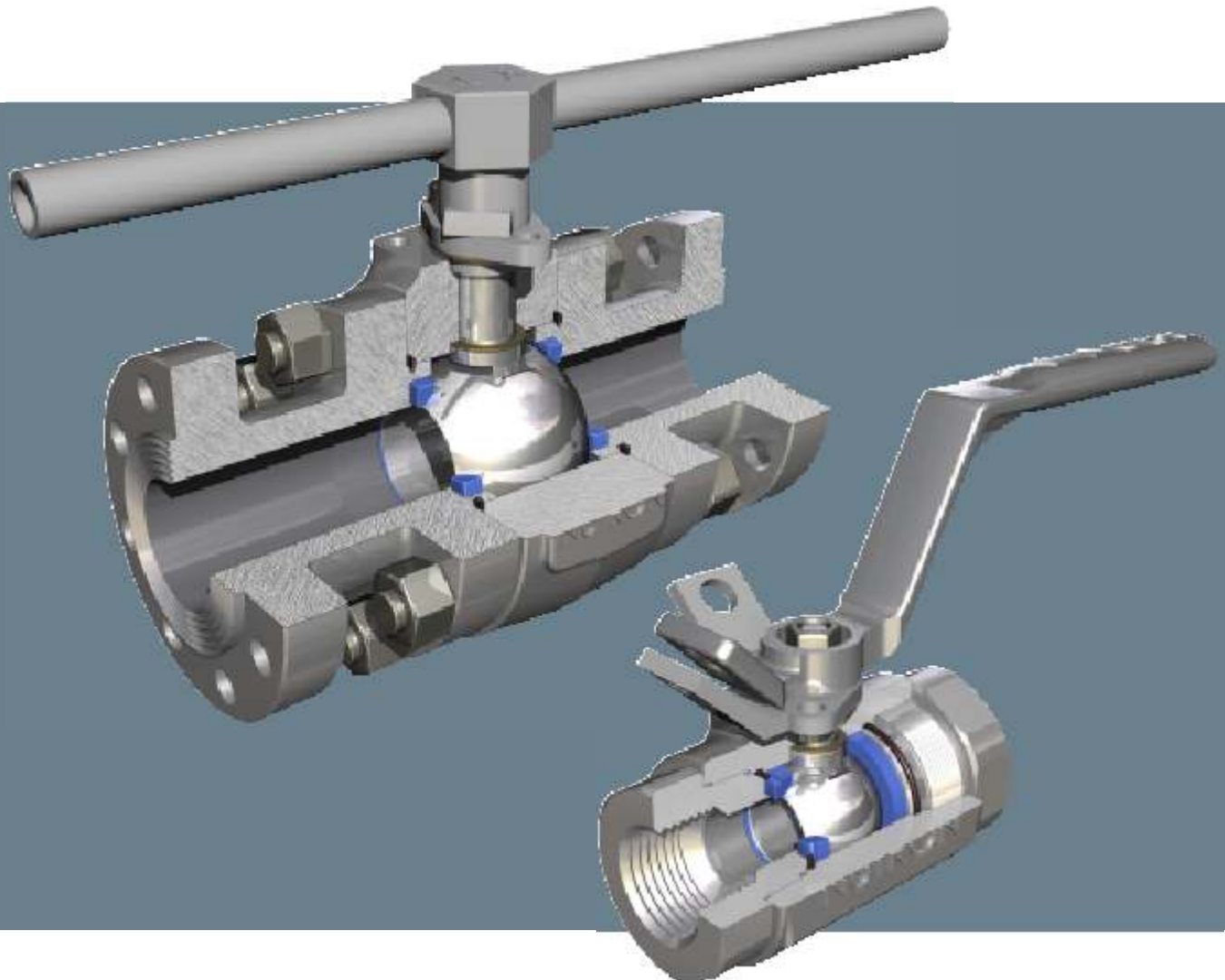

NUTRON[®]

TABLE OF CONTENTS

MODEL T3 & B3 FORGED STEEL FLOATING BALL VALVES	
Sizes, Specifications & Compliance	1
MODEL T3	
Features	2
ORDER INFORMATION	3
Valve Details & Material Lists	4 through 9
Dimension Tables - Valve Assemblies	10 through 15
MODEL B3	
Features	16
ORDER INFORMATION	17
Valve Details & Material Lists	18 through 23
Dimension Tables - Valve Assemblies	24 & 25
T3 Actuator Mounting Dimensions	25
B3 Actuator Mounting Dimensions	26
PRESSURE, TEMPERATURE RATINGS AND TORQUE TABLES	27
TRADEMARK INFORMATION	28
TERMS AND CONDITIONS	29

FORGED STEEL FLOATING BALL VALVES

MODEL T3 3 PIECE THREADED FLOATING BALL VALVES

- Full Port sizes 1/2 in. through 3 in. (15 mm through 80 mm)
- Reduced Port sizes 3/4 in. through 4 in. (20 mm through 100 mm)
- ASME Class 150 through 2500 (PN 20 through 420) (see page 3)
- WOG 1000 through 6000 psi (see page 3)
- End Connections: Threaded, Flanged, Socket Weld, Buttweld

MODEL B3 3 PIECE BOLTED FLOATING BALL VALVES

- Full Port sizes 1 1/2 in. through 4 in. (40 mm through 100 mm)
- Reduced Port sizes 2 in. and 6 in. (50 mm and 150 mm)
- ASME Class 150 through 1500 (PN 20 through 250) (see page 17)
- WOG 2000 and 4000 psi (see page 17)
- End Connections: Flanged, Threaded, Buttweld

MATERIALS AND ACTUATION

- Materials: Carbon Steel, Stainless Steel, Special Alloys
- Operator: Manual Lever Handle
- Actuation: Consult Cameron, Valves & Measurement Sales Department for information on various types of actuators including: Gear Operators (B3), Pneumatic, Hydro-Pneumatic, Electric, Electro-Pneumatic and Hydraulic

COMPLIANCE TO STANDARDS AND SPECIFICATIONS:

- ISO 9001-2000: Registered Quality System
- ASME B16.34
- API 598 and API 607 4th Edition (Fire Safe)
- CE Mark Number 0879
- ASME Section VIII Division 1 Boiler and Pressure Vessel Code
- CSA Z245.15 Steel Valves
- NACE MR0175 (Rev. 2002)
- Canadian Registration Number (CRN)

FORGED STEEL FLOATING BALL VALVES STANDARD FEATURES

MODEL T3

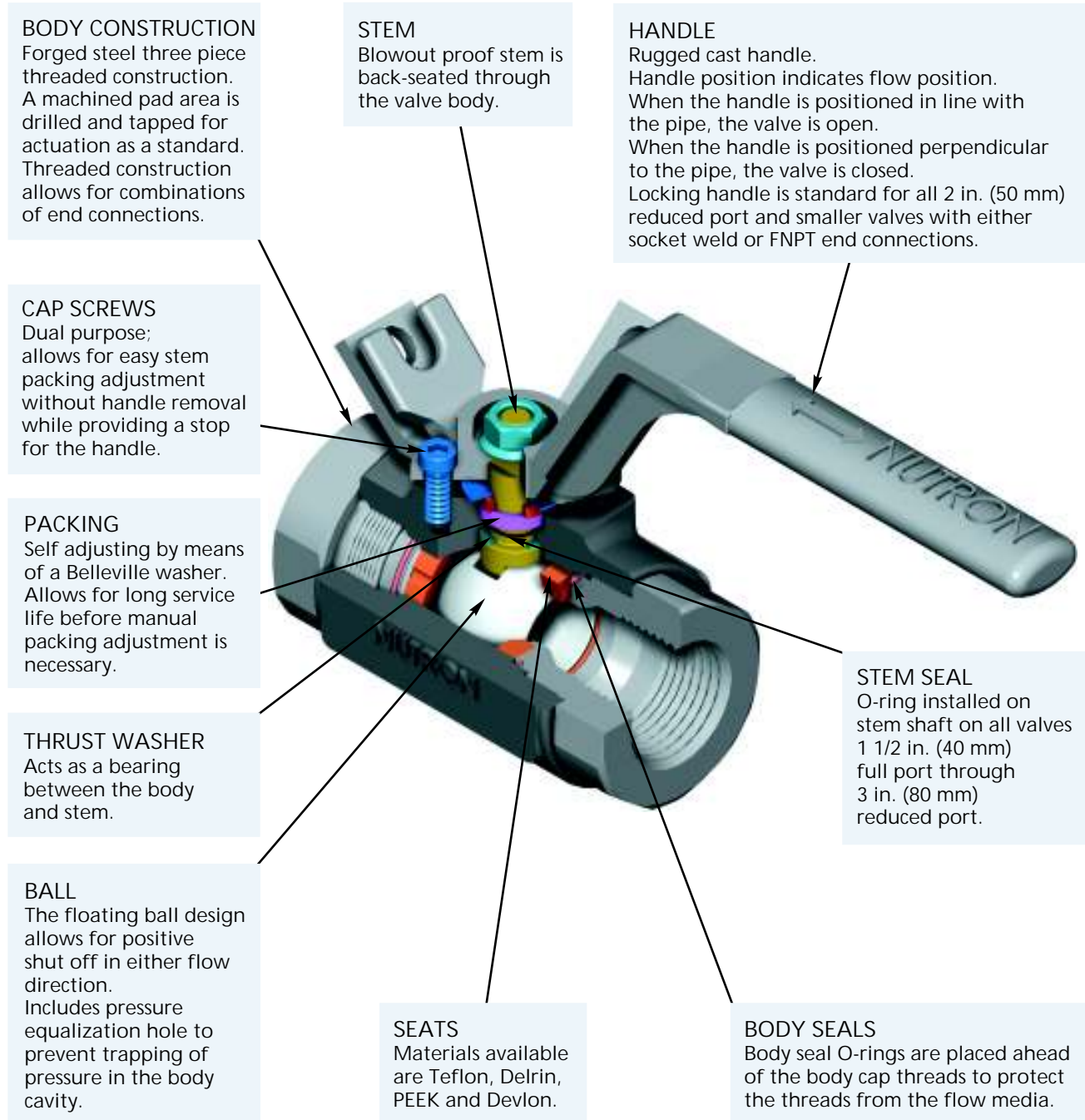

FORGED STEEL FLOATING BALL VALVES MODEL T3 SIZES AVAILABLE

ASME CLASS (PN)	150 (20)	300 (50)	600 (100)	900 (150)	1500 (250)	2500 (420)
Full Port Excluding 1 in. (25 mm)	in. 1/2 thru 3 (mm) (15 thru 80)	1/2 thru 3 (15 thru 80)	1/2 thru 2 (15 thru 50)	1/2 thru 2 (15 thru 50)	1/2 thru 2 (15 thru 50)	1/2 thru 2 (15 thru 50)
Reduced Port Excluding 1 1/2 in. (40 mm)	3/4 thru 4 (20 thru 100)	3/4 thru 4 (20 thru 100)	3/4 thru 3 (20 thru 100)	3/4 thru 3 (20 thru 80)	3/4 thru 3 (20 thru 80)	3/4 thru 3 (20 thru 80)
WOG (psi)		1000	2000	3000	4000	6000
Full Port, Threaded	in. (mm)	3 (80)	1/4 thru 3 (8 thru 80)	1/4 thru 2 (8 thru 50)	1/4 thru 2 (8 thru 50)	1/4 thru 2 (8 thru 50)
Reduced Port, Threaded		4 (100)	3/4 thru 3 (20 thru 80)	3/4 thru 3 (20 thru 80)	3/4 thru 3 (20 thru 80)	3/4 thru 3 (20 thru 80)
Full Port, Socket Weld			1/2 thru 2 (15 thru 50)	1/2 thru 2 (15 thru 50)	1/2 thru 2 (15 thru 50)	1/2 thru 2 (15 thru 50)
Reduced Port, Socket Weld			3/4 thru 3 (20 thru 80)	3/4 thru 3 (20 thru 80)	3/4 thru 3 (20 thru 80)	3/4 thru 3 (20 thru 80)

ORDERING INFORMATION

How to develop typical figure numbers without options:

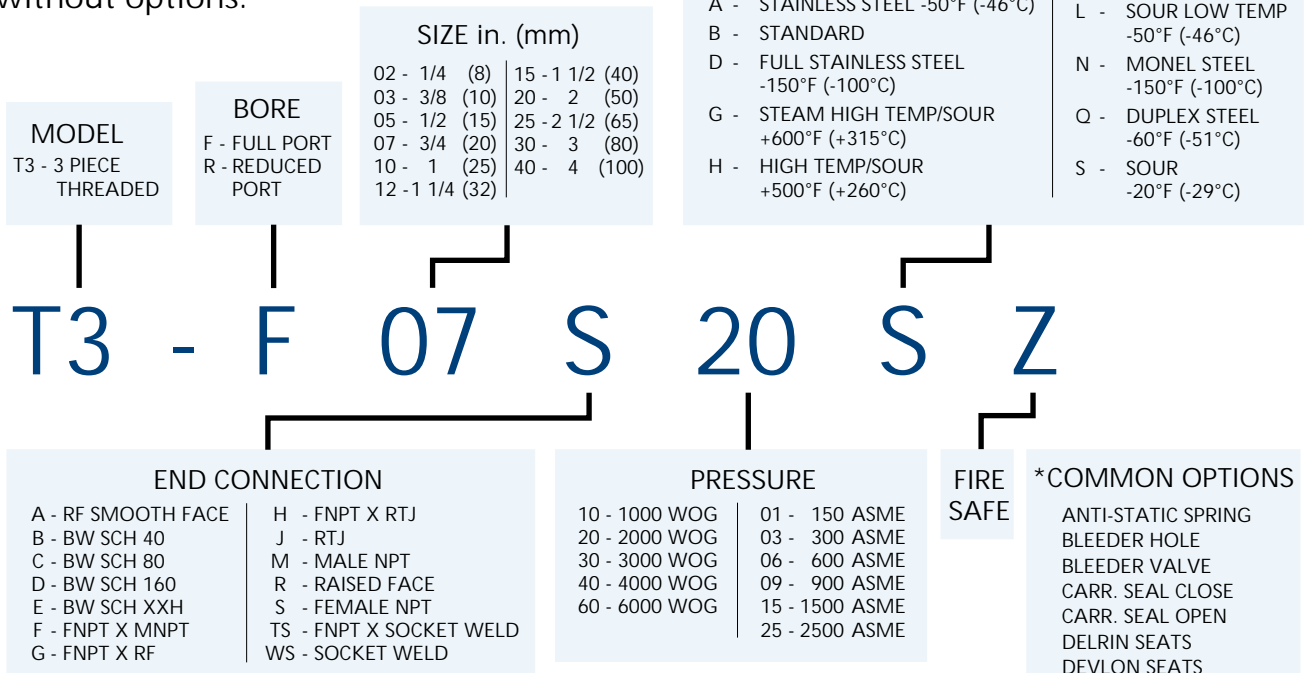

Examples:

T3-F07S20SZ = Model T3, Full Port, 3/4 in. (20 mm), Female NPT, 2000 WOG, Sour Valve, Fire Safe.

T3-R10TS30B = Model T3, Reduced Port, 1 in. (25 mm), Female NPT x Socket Weld, 3000 WOG, Standard Valve.

* Consult Cameron, Valves & Measurement Sales Department for detailed valve style descriptions, full range of options, materials, actuation packages or for a particular special valve service application.

Cameron reserves the right to substitute materials listed on the following pages with alternate materials for the designated service.

FORGED STEEL FLOATING BALL VALVES
MODEL T3 THREADED END CONNECTIONS

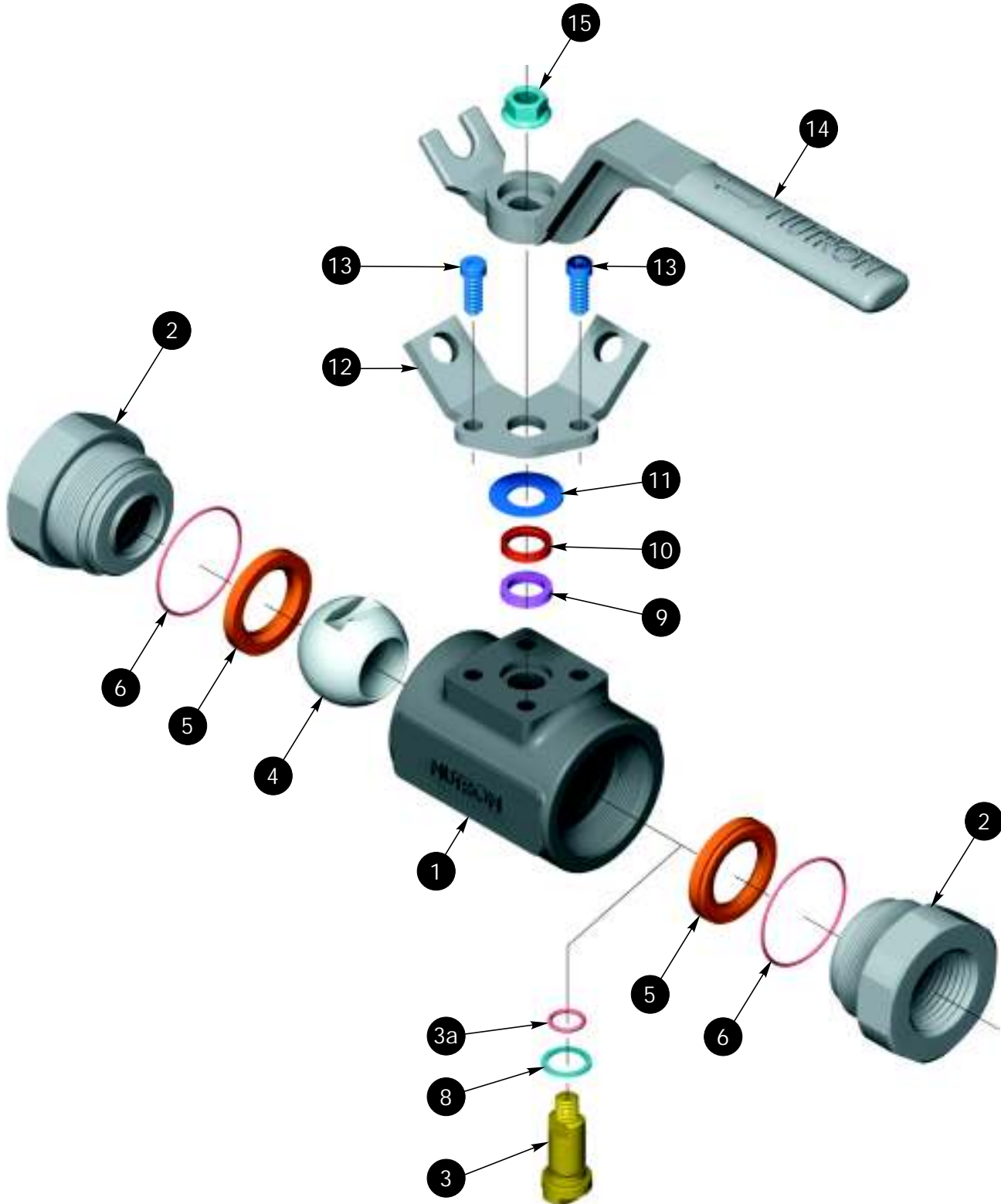

FORGED STEEL FLOATING BALL VALVES MODEL T3 MATERIALS LIST - THREADED END CONNECTIONS

ITEM	PART	WORKING PRESSURE	STANDARD -20°F (-29°C)	SOUR -20°F (-29°C)
1	Body	All	ASTM A105	ASTM A105
2	End Caps	All	ASTM A105	ASTM A105
□ 3	Stem	2000 & 3000 4000 & 6000	ASTM A108, Plated ASTM A564 17-4PH	ASTM A564 17-4PH ASTM A564 17-4PH
□ ! 3a*	Stem O-Ring	All	Buna	Viton
□ 4	Ball	2000, 3000 & 4000 6000	Carbon Steel, Chrome Plated ASTM A564 17-4PH	ASTM A351 Gr. CF8M ASTM A564 17-4PH
□ ! 5	Seats	2000 3000 & 4000 6000	Teflon Delrin PEEK	Teflon Delrin PEEK
□ ! 6	Body O-Rings	All	Buna	Viton
□ ! 8	Thrust Washer	2000 3000 & 4000 6000	Teflon Delrin PEEK	Teflon Delrin PEEK
□ ! 9	Packing	All	Teflon (Graphite 6000 psi)	Teflon (Graphite 6000 psi)
10	Packing Follower	All	Carbon Steel, Plated	Stainless Steel
11	Belleville Washer	All	Carbon Steel	Stainless Steel
12	Gland Flange **	All	Carbon Steel, Plated	Carbon Steel, Plated
13	Cap Screws	All	Carbon Steel	Stainless Steel
14	Handle	All	Carbon Steel	Carbon Steel
15	Handle Nut	All	Carbon Steel, Plated	Carbon Steel, Plated

ITEM	PART	WORKING PRESSURE	SOUR & LOW TEMP -50°F (-46°C)	STAINLESS STEEL -50°F (-46°C)
1	Body	All	ASTM A350 LF2	ASTM A479 TYPE 316
2	End Caps	All	ASTM A350 LF2	ASTM A479 TYPE 316
□ 3	Stem	All	ASTM A564 17-4PH	ASTM A564 17-4PH with Nitriding
□ ! 3a*	Stem O-Ring	All	HSN	HSN
□ 4	Ball	2000 3000 & 4000 6000	ASTM A351 Gr. CF8M ASTM A351 Gr. CF8M ASTM A564 17-4PH	ASTM A351 Gr. CF8M ASTM A564 17-4PH ASTM A564 17-4PH
□ ! 5	Seats	2000 3000 & 4000 6000	Teflon Delrin PEEK	Teflon PEEK PEEK
□ ! 6	Body O-Rings	All	HSN	Teflon
□ ! 8	Thrust Washer	2000 3000 & 4000 6000	Teflon Delrin PEEK	Teflon PEEK PEEK
□ ! 9	Packing	All	Teflon (Graphite 6000 psi)	Teflon (Graphite 6000 psi)
10	Packing Follower	All	Stainless Steel	Stainless Steel
11	Belleville Washer	All	Stainless Steel	Stainless Steel
12	Gland Flange **	All	Carbon Steel, Plated	Carbon Steel, Plated
13	Cap Screws	All	Stainless Steel	Stainless Steel
14	Handle	All	Carbon Steel	Carbon Steel
15	Handle Nut	All	Carbon Steel, Plated	Carbon Steel, Plated

□ Major repair kit.

! Minor repair kit.

* Item 3a is only available on sizes 1 1/2 in. full port through 3 in. reduced port (40 mm through 80 mm) valves.

** Locking device is standard on 1/4 in. full port through 2 in. reduced port (8 mm through 50 mm) valves.

Note: Fire safe trim offered as standard whenever possible.

Consult Cameron, Valves & Measurement Sales Department for fire safe trim.

FORGED STEEL FLOATING BALL VALVES
 MODEL T3 SOCKET WELD and
 THREADED x SOCKET WELD END CONNECTIONS

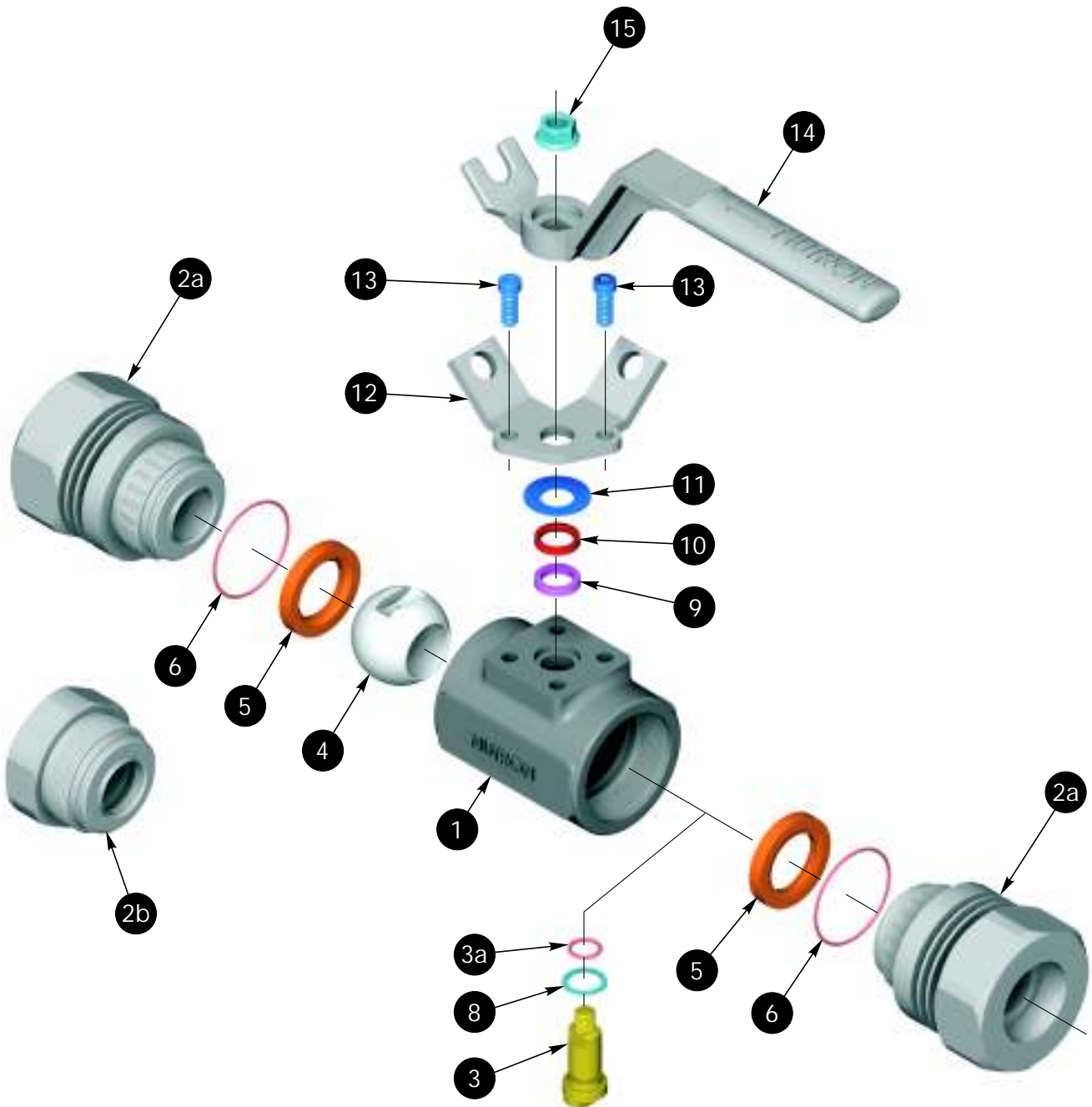

FORGED STEEL FLOATING BALL VALVES MODEL T3 MATERIALS LIST SOCKET WELD and THREADED x SOCKET WELD END CONNECTIONS

ITEM	PART	WORKING PRESSURE	STANDARD -20°F (-29°C)	SOUR -20°F (-29°C)
1	Body	All	ASTM A105	ASTM A105
2a	End Caps - SW	All	ASTM A350 Gr. LF2	ASTM A350 Gr. LF2
2b	End Cap - NPT	All	ASTM A105	ASTM A105
□ 3	Stem	2000 & 3000 4000 & 6000	ASTM A108, Plated ASTM A564 17-4PH	ASTM A564 17-4PH ASTM A564 17-4PH
□! 3a*	Stem O-Ring	All	HSN	Viton
□ 4	Ball	2000 3000, 4000 & 6000	ASTM A351 Gr. CF8M ASTM A564 17-4PH	ASTM A351 Gr. CF8M ASTM A564 17-4PH
□! 5	Seats	2000 3000, 4000 & 6000	Teflon PEEK	Teflon PEEK
□! 6	Body O-Rings	All	Viton	Viton
□! 8	Thrust Washer	2000 3000, 4000 & 6000	Teflon PEEK	Teflon PEEK
□! 9	Packing	All	Teflon (Graphite - 3000 thru 6000)	Teflon (Graphite - 3000 thru 6000)
10	Packing Follower	All	Carbon Steel, Plated	Stainless Steel
11	Belleville Washer	All	Carbon Steel	Stainless Steel
12	Gland Flange **	All	Carbon Steel, Plated	Carbon Steel, Plated
13	Cap Screws	All	Carbon Steel	Stainless Steel
14	Handle	All	Carbon Steel	Carbon Steel
15	Handle Nut	All	Carbon Steel, Plated	Carbon Steel, Plated

ITEM	PART	WORKING PRESSURE	SOUR & LOW TEMP -50°F (-46°C)	STAINLESS STEEL -50°F (-46°C)
1	Body	All	ASTM A350 LF2	ASTM A479 TYPE 316
2a	End Caps - SW	All	ASTM A350 LF2	ASTM A479 TYPE 316 L
2b	End Cap - NPT	All	ASTM A350 LF2	ASTM A479 TYPE 316
□ 3	Stem	All	ASTM A564 17-4PH	ASTM A564 17-4PH with Nitriding
□! 3a*	Stem O-Ring	All	Viton	HSN
□ 4	Ball	2000 3000, 4000 & 6000	ASTM A351 Gr. CF8M ASTM A564 17-4PH	ASTM A351 Gr. CF8M ASTM A564 17-4PH
□! 5	Seats	2000 3000, 4000 & 6000	Teflon PEEK	Teflon PEEK
□! 6	Body O-Rings	All	Viton	Teflon
□! 8	Thrust Washer	2000 3000, 4000 & 6000	Teflon PEEK	Teflon PEEK
□! 9	Packing	All	Teflon (Graphite - 3000 thru 6000)	Teflon (Graphite - 3000 thru 6000)
10	Packing Follower	All	Stainless Steel	Stainless Steel
11	Belleville Washer	All	Stainless Steel	Stainless Steel
12	Gland Flange **	All	Carbon Steel, Plated	Carbon Steel, Plated
13	Cap Screws	All	Stainless Steel	Stainless Steel
14	Handle	All	Carbon Steel	Carbon Steel
15	Handle Nut	All	Carbon Steel, Plated	Carbon Steel, Plated

□ Major repair kit.

! Minor repair kit.

* Item 3a is only available on sizes 1 1/2 in. full port through 3 in. reduced port (40 mm through 80 mm) valves.

** Locking device is standard on 1/4 in. full port through 2 in. reduced port (8 mm through 50 mm) valves.

Note: Fire safe trim offered as standard whenever possible.

Consult Cameron, Valves & Measurement Sales Department for fire safe trim.

FORGED STEEL FLOATING BALL VALVES
MODEL T3 FLANGED END CONNECTIONS

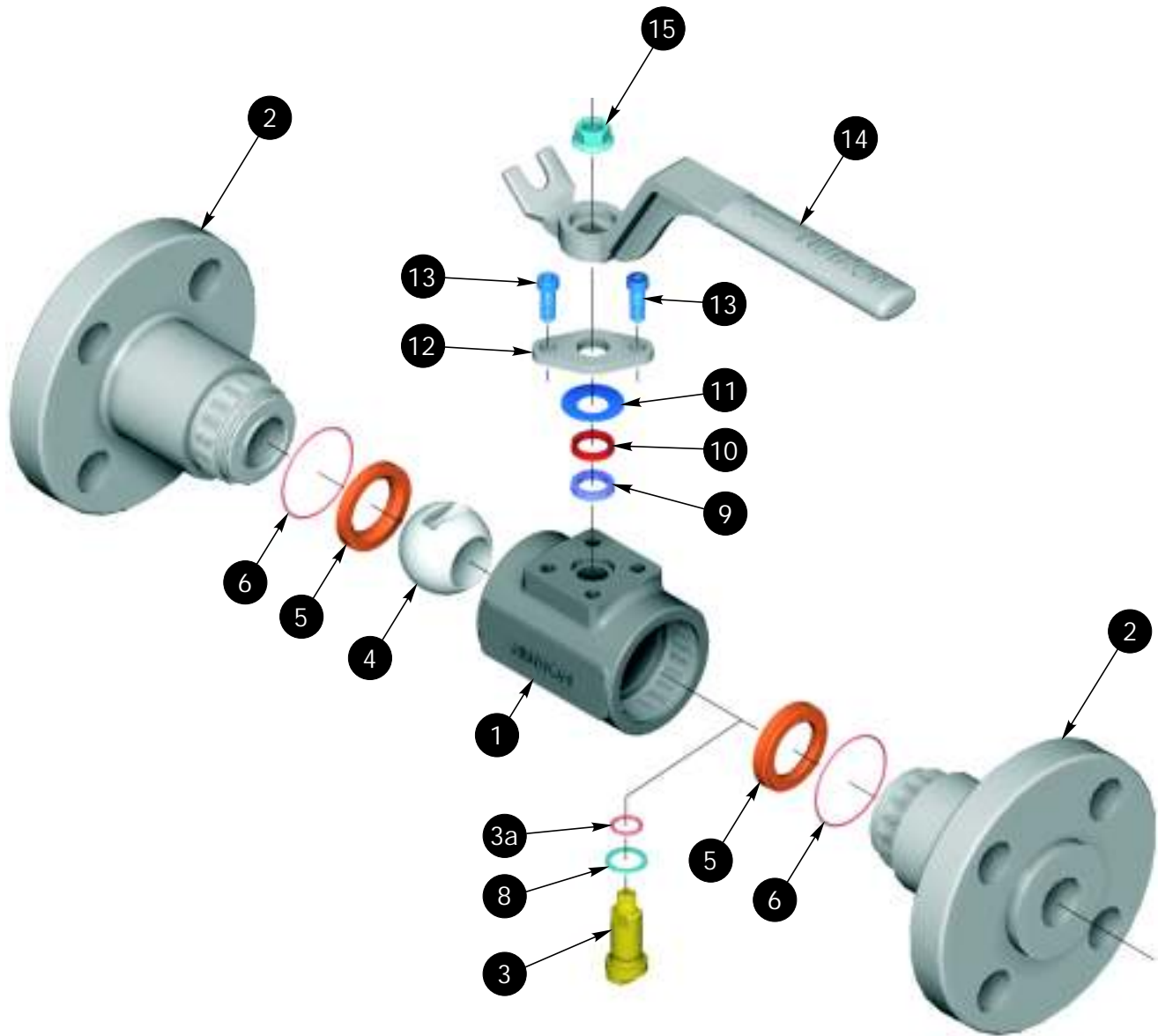

FORGED STEEL FLOATING BALL VALVES MODEL T3 MATERIALS LIST - FLANGED END CONNECTIONS ASME CLASS 150 THROUGH 2500 (PN 20 THROUGH 420)

ITEM	PART	ASME CLASS	STANDARD -20°F (-29°F)	SOUR -20°F (-29°C)
1	Body	All	ASTM A105	ASTM A105
2	End Caps	All	ASTM A105	ASTM A105
□ 3	Stem	150, 300, 600 & 900 1500 & 2500	ASTM A108, Plated ASTM A564 17-4PH	ASTM A564 17-4PH ASTM A564 17-4PH
□ ! 3a*	Stem O-Ring	All	Buna	Viton
□ 4	Ball	150 thru 1500 2500	Carbon Steel, Chrome Plated ASTM A564 17-4PH	ASTM A351 Gr. CF8M ASTM A564 17-4PH
□ ! 5	Seats	150, 300 & 600 900 & 1500 2500	Teflon Delrin PEEK	Teflon Delrin PEEK
□ ! 6	Body O-Rings	All	Buna	Viton
□ ! 8	Thrust Washer	150, 300 & 600 900 & 1500 2500	Teflon Delrin PEEK	Teflon Delrin PEEK
□ ! 9	Packing	All	Teflon (Graphite - 2500 ASME)	Teflon (Graphite - 2500 ASME)
10	Packing Follower	All	Carbon Steel, Plated	Stainless Steel
11	Belleville Washer	All	Carbon Steel	Stainless Steel
12	Gland Flange	All	Carbon Steel, Plated	Carbon Steel, Plated
13	Cap Screws	All	Carbon Steel	Stainless Steel
14	Handle	All	Carbon Steel	Carbon Steel
15	Handle Nut	All	Carbon Steel, Plated	Carbon Steel, Plated

ITEM	PART	ASME CLASS	SOUR & LOW TEMP -50°F (-46°C)	STAINLESS STEEL -50°F (-46°C)
1	Body	All	ASTM A350 LF2	ASTM A479 TYPE 316
2	End Caps	All	ASTM A350 LF2	ASTM A479 TYPE 316
□ 3	Stem	All	ASTM A564 17-4PH	ASTM A564 17-4PH with Nitriding
□ ! 3a*	Stem O-Ring	All	HSN	HSN
□ 4	Ball	150, 300 & 600 900 & 1500 2500	ASTM A351 Gr. CF8M ASTM A351 Gr. CF8M ASTM A564 17-4PH	ASTM A351 Gr. CF8M ASTM A564 17-4PH ASTM A564 17-4PH
□ ! 5	Seats	150, 300 & 600 900 & 1500 2500	Teflon Delrin PEEK	Teflon PEEK PEEK
□ ! 6	Body O-Rings	All	HSN	Teflon
□ ! 8	Thrust Washer	150, 300 & 600 900 & 1500 2500	Teflon Delrin PEEK	Teflon PEEK PEEK
□ ! 9	Packing	All	Teflon (Graphite - 2500 ASME)	Teflon (Graphite - 1500 & 2500 ASME)
10	Packing Follower	All	Stainless Steel	Stainless Steel
11	Belleville Washer	All	Stainless Steel	Stainless Steel
12	Gland Flange	All	Carbon Steel, Plated	Carbon Steel, Plated
13	Cap Screws	All	Stainless Steel	Stainless Steel
14	Handle	All	Carbon Steel	Carbon Steel
15	Handle Nut	All	Carbon Steel, Plated	Carbon Steel, Plated

□ Major repair kit.

! Minor repair kit.

* Item 3a is only available on sizes 1 1/2 in. full port through 3 in. reduced port (40 mm through 80 mm) valves.

Note: Fire safe trim offered as standard whenever possible.

Consult Cameron, Valves & Measurement Sales Department for fire safe trim.

FORGED STEEL FLOATING BALL VALVES MODEL T3 FULL PORT - THREADED

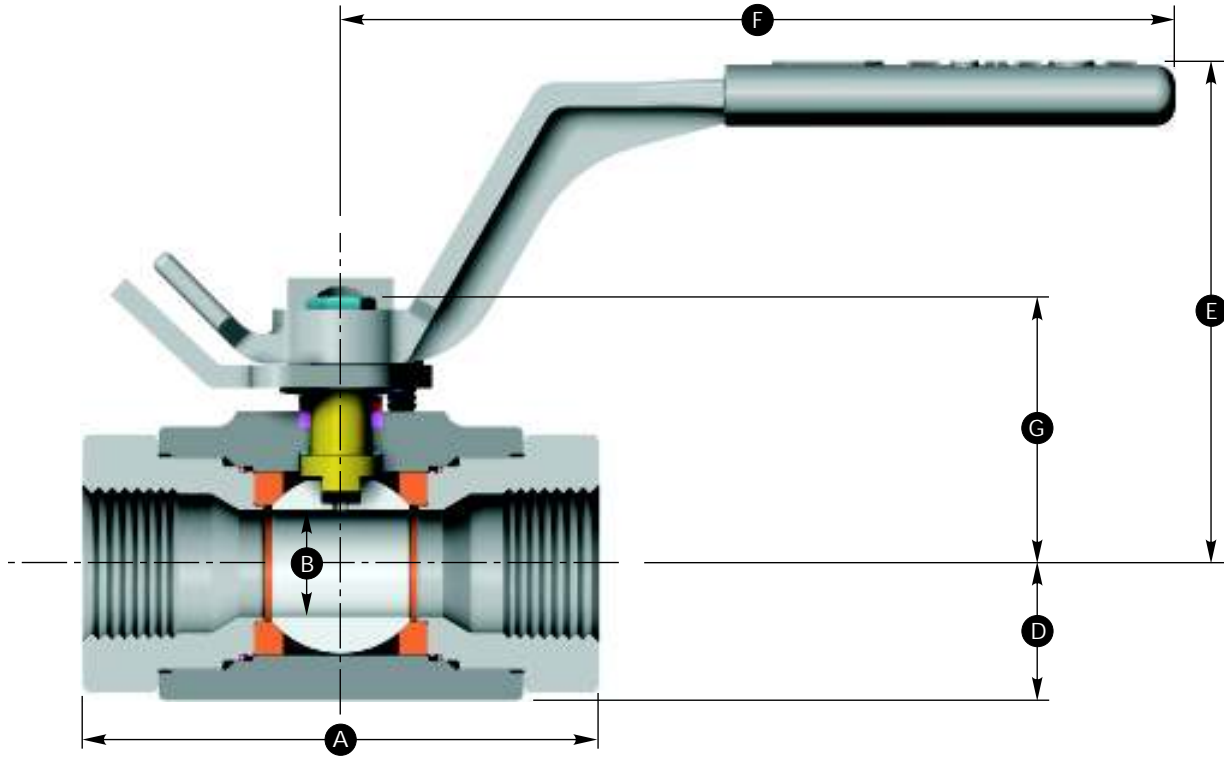

DIMENSIONS

SIZE in. (mm)	WOG	A	B	D	E	F	G	C _v	WEIGHT lb. (kg)
1/4 (8)	2000	3.88 (98)	0.50 (13)	0.82 (21)	3.29 (83)	4.82 (122)	1.73 (44)	9	2.5 (1.1)
	3000	3.88 (98)	0.50 (13)	0.82 (21)	3.29 (83)	4.82 (122)	1.73 (44)	9	2.5 (1.1)
	4000	3.88 (98)	0.50 (13)	0.82 (21)	3.29 (83)	4.82 (122)	1.73 (44)	9	2.5 (1.1)
	6000	3.88 (98)	0.50 (13)	0.82 (21)	3.29 (83)	4.82 (122)	1.73 (44)	9	2.5 (1.1)
3/8 (10)	2000	3.88 (98)	0.50 (13)	0.82 (21)	3.29 (83)	4.82 (122)	1.73 (44)	9	2.4 (1.0)
	3000	3.88 (98)	0.50 (13)	0.82 (21)	3.29 (83)	4.82 (122)	1.73 (44)	9	2.4 (1.0)
	4000	3.88 (98)	0.50 (13)	0.82 (21)	3.29 (83)	4.82 (122)	1.73 (44)	9	2.4 (1.0)
	6000	3.88 (98)	0.50 (13)	0.82 (21)	3.29 (83)	4.82 (122)	1.73 (44)	9	2.4 (1.0)
1/2 (15)	2000	3.88 (98)*	0.50 (13)	0.82 (21)	3.29 (83)	4.82 (122)	1.73 (44)	26	2.2 (0.9)
	3000	3.88 (98)*	0.50 (13)	0.82 (21)	3.29 (83)	4.82 (122)	1.73 (44)	26	2.2 (0.9)
	4000	3.88 (98)*	0.50 (13)	0.82 (21)	3.29 (83)	4.82 (122)	1.73 (44)	26	2.2 (0.9)
	6000	4.38 (111)	0.50 (13)	0.82 (21)	3.29 (83)	4.82 (122)	1.73 (44)	26	2.2 (0.9)
3/4 (20)	2000	4.25 (108)	0.88 (22)	1.12 (29)	4.40 (112)	6.75 (172)	2.16 (55)	50	4.8 (2.1)
	3000	4.25 (108)	0.88 (22)	1.12 (29)	4.40 (112)	6.75 (172)	2.16 (55)	50	4.8 (2.1)
	4000	4.25 (108)	0.88 (22)	1.12 (29)	4.40 (112)	6.75 (172)	2.16 (55)	50	4.8 (2.1)
	6000	4.25 (108)	0.88 (22)	1.50 (38)	4.40 (112)	6.75 (172)	2.16 (55)	50	6.5 (2.9)
1 1/2 (40)	2000	6.25 (159)	1.50 (38)	1.98 (50)	5.62 (143)	11.00 (279)	3.52 (89)	260	18.0 (8.1)
	3000	6.25 (159)	1.50 (38)	1.98 (50)	5.62 (143)	11.00 (279)	3.52 (89)	260	18.0 (8.1)
	4000	6.25 (159)	1.50 (38)	1.98 (50)	5.62 (143)	11.00 (279)	3.52 (89)	260	18.0 (8.1)
	6000	6.25 (159)	1.50 (38)	1.98 (50)	5.62 (143)	11.00 (279)	3.52 (89)	260	18.0 (8.1)
2 (50)	2000	6.25 (159)	2.00 (51)	2.53 (64)	6.96 (177)	11.88 (302)	4.83 (123)	480	30.0 (13.6)
	3000	6.25 (159)	2.00 (51)	2.53 (64)	6.96 (177)	11.88 (302)	4.83 (123)	480	30.0 (13.6)
	4000	6.25 (159)	2.00 (51)	2.53 (64)	6.96 (177)	11.88 (302)	4.83 (123)	480	30.0 (13.6)
	6000	6.25 (159)	2.00 (51)	2.53 (64)	6.96 (177)	11.88 (302)	4.83 (123)	480	30.0 (13.6)
3 (80)	1000	9.70 (246)	3.00 (76)	3.50 (89)	8.26 (210)	23.88 (607)	5.37 (137)	1300	67.0 (30.4)
	2000	9.70 (246)	3.00 (76)	3.50 (89)	8.26 (210)	23.88 (607)	5.37 (137)	1300	67.0 (30.4)

* 4.38 in. (111 mm) for Stainless Steel valves.

NOTE: " A " dimension to be within ± 0.062 in. (1.5 mm).

FORGED STEEL FLOATING BALL VALVES MODEL T3 REDUCED PORT - THREADED

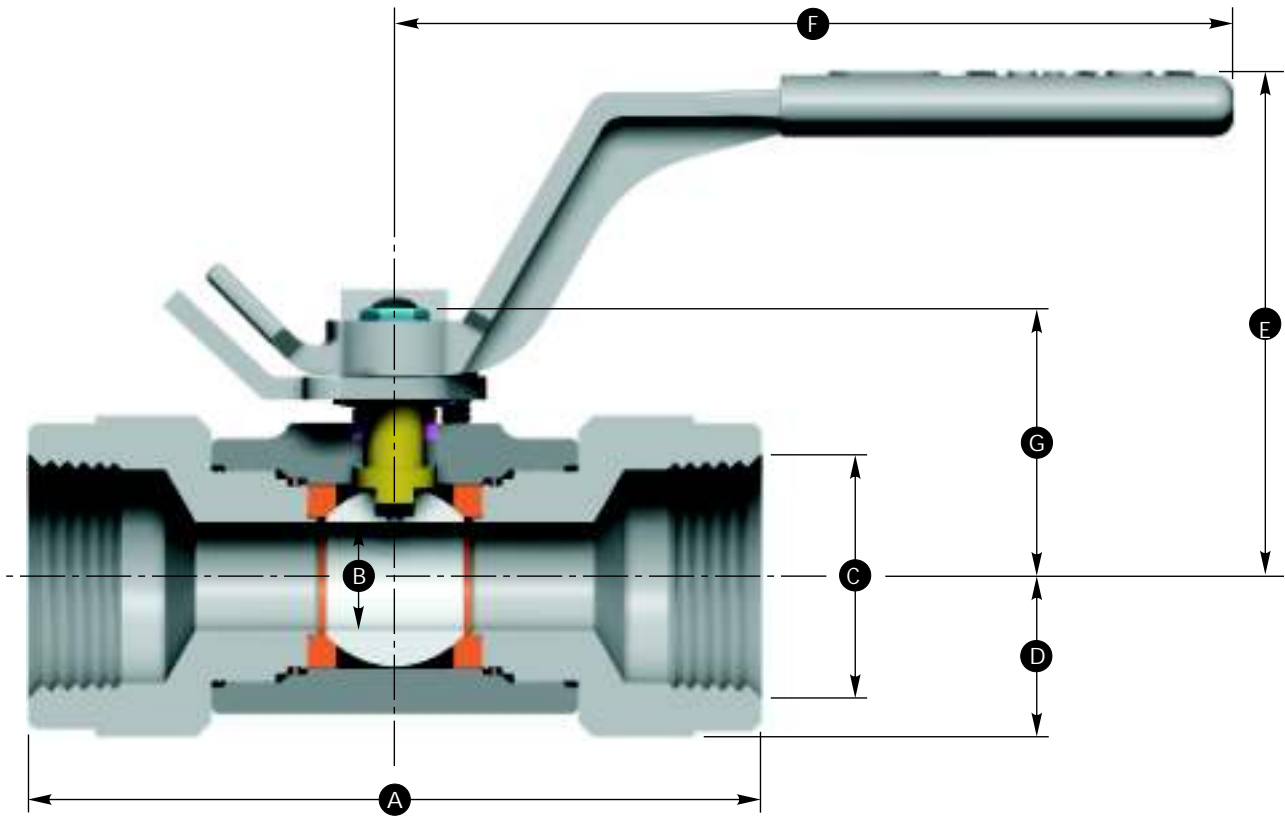

DIMENSIONS

SIZE in. (mm)	WOG	A	B	C	D	E	F	G	C _v	WEIGHT lb. (kg)
3/4 (20)	2000	4.38 (111)	0.50 (13)	0.75 (19)	0.82 (21)	3.29 (83)	4.82 (122)	1.73 (44)	14	2.5 (1.1)
	3000	4.38 (111)	0.50 (13)	0.75 (19)	0.82 (21)	3.29 (83)	4.82 (122)	1.73 (44)	14	2.5 (1.1)
	4000	4.38 (111)	0.50 (13)	0.75 (19)	0.82 (21)	3.29 (83)	4.82 (122)	1.73 (44)	14	2.5 (1.1)
	6000	4.38 (111)	0.50 (13)	0.75 (19)	0.82 (21)	3.29 (83)	4.82 (122)	1.73 (44)	14	2.5 (1.1)
1 (25)	2000	4.25 (108)	0.88 (22)	1.00 (25)	1.12 (28)	4.40 (112)	6.75 (172)	2.16 (55)	35	4.5 (2.0)
	3000	4.25 (108)	0.88 (22)	1.00 (25)	1.12 (28)	4.40 (112)	6.75 (172)	2.16 (55)	35	4.5 (2.0)
	4000	4.25 (108)	0.88 (22)	1.00 (25)	1.12 (28)	4.40 (112)	6.75 (172)	2.16 (55)	35	4.5 (2.0)
	6000	5.25 (133)	0.88 (22)	1.00 (25)	1.50 (38)	4.40 (112)	6.75 (172)	2.16 (55)	35	7.5 (3.4)
1 1/4 (32)	2000	6.00 (152)	0.88 (22)	1.25 (32)	1.30 (33)	4.40 (112)	6.75 (172)	2.16 (55)	35	8.0 (3.6)
	3000	6.00 (152)	0.88 (22)	1.25 (32)	1.30 (33)	4.40 (112)	6.75 (172)	2.16 (55)	35	8.0 (3.6)
2 (50)	2000	6.25 (159)	1.50 (38)	2.00 (51)	1.98 (50)	5.62 (143)	11.00 (279)	3.52 (89)	100	17.5 (7.9)
	3000	6.25 (159)	1.50 (38)	2.00 (51)	1.98 (50)	5.62 (143)	11.00 (279)	3.52 (89)	100	17.5 (7.9)
	4000	6.25 (159)	1.50 (38)	2.00 (51)	1.98 (50)	5.62 (143)	11.00 (279)	3.52 (89)	100	17.5 (7.9)
	6000	7.25 (184)	1.50 (38)	2.00 (51)	1.98 (50)	5.62 (143)	11.00 (279)	3.52 (89)	100	21.0 (9.5)
3 (80)	2000	10.0 (254)	2.00 (51)	3.00 (76)	2.53 (64)	6.96 (177)	11.88 (302)	4.83 (123)	420	39.0 (17.6)
	3000	10.0 (254)	2.00 (51)	3.00 (76)	2.53 (64)	6.96 (177)	11.88 (302)	4.83 (123)	420	39.0 (17.6)
	4000	10.0 (254)	2.00 (51)	3.00 (76)	2.53 (64)	6.96 (177)	11.88 (302)	4.83 (123)	420	39.0 (17.6)
	6000	10.0 (254)	2.00 (51)	3.00 (76)	2.53 (64)	6.96 (177)	11.88 (302)	4.83 (123)	420	48.0 (21.8)
4 (100)	1000	9.5 (241)	3.00 (76)	4.00 (102)	3.50 (89)	8.26 (210)	23.88 (607)	5.37 (137)	770	80.0 (36.3)

NOTE: " A " dimension to be within ± 0.062 in. (1.5 mm).

FORGED STEEL FLOATING BALL VALVES

MODEL T3 FULL PORT - SOCKET WELD & THREADED x SOCKET WELD

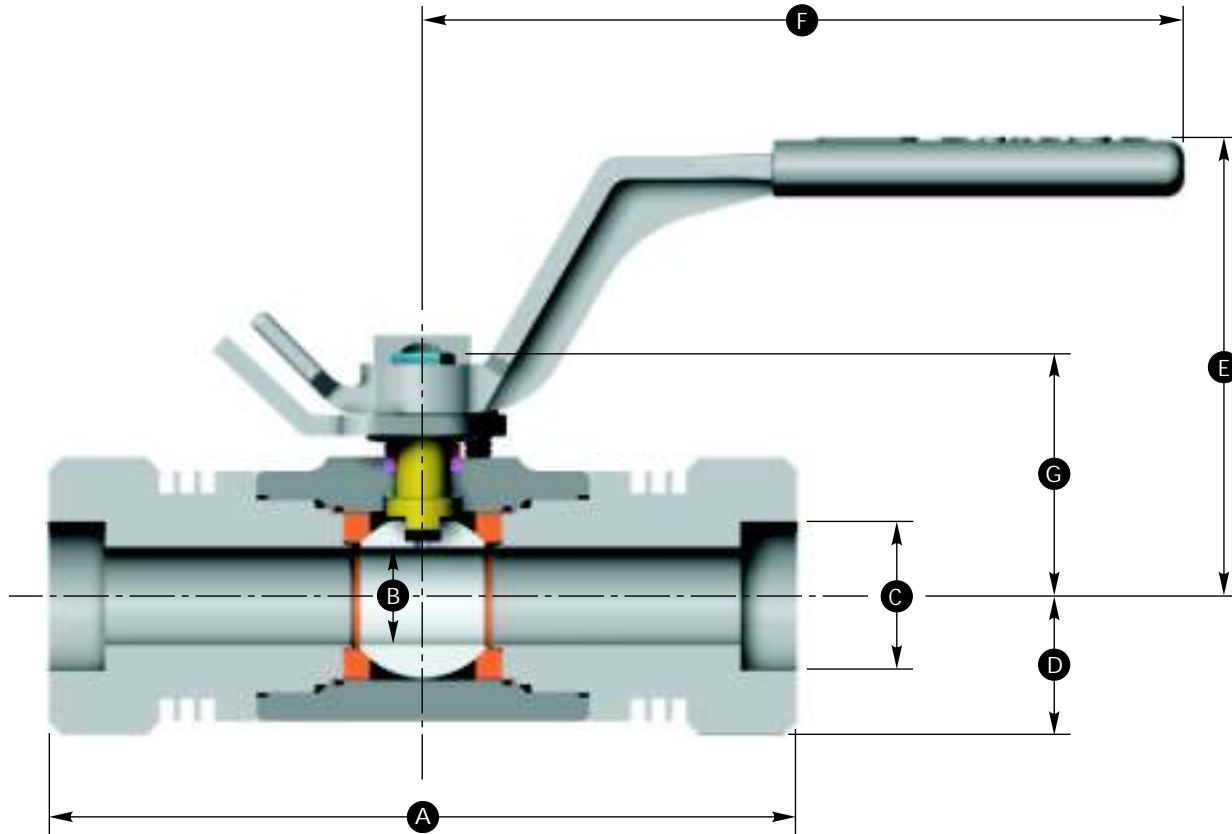

DIMENSIONS

SIZE in. (mm)	WOG	A		B	C		D	E	F	G	C _v	WEIGHT lb. (kg)	
		FNPT x SW	SW		FNPT x SW	SW						FNPT x SW	SW
1/2 (15)	2000	4.44 (113)*	5.00 (127)	0.50 (13)	0.50 (13)	0.86 (22)	0.94 (24)	3.29 (83)	4.82 (122)	1.73 (44)	26	3.5 (1.5)	4.8 (2.1)
	3000	4.44 (113)*	5.00 (127)	0.50 (13)	0.50 (13)	0.86 (22)	0.94 (24)	3.29 (83)	4.82 (122)	1.73 (44)	26	3.5 (1.5)	4.8 (2.1)
	4000	4.44 (113)*	5.00 (127)	0.50 (13)	0.50 (13)	0.86 (22)	0.94 (24)	3.29 (83)	4.82 (122)	1.73 (44)	26	3.5 (1.5)	4.8 (2.1)
	6000	4.69 (119)	5.00 (127)	0.50 (13)	0.50 (13)	0.86 (22)	0.94 (24)	3.29 (83)	4.82 (122)	1.73 (44)	26	3.5 (1.5)	4.8 (2.1)
3/4 (20)	2000	5.50 (140)	6.75 (172)	0.88 (22)	0.75 (19)	1.07 (27)	1.25 (32)	4.40 (112)	6.75 (172)	2.16 (55)	50	5.7 (2.5)	6.4 (2.9)
	3000	5.50 (140)	6.75 (172)	0.88 (22)	0.75 (19)	1.07 (27)	1.25 (32)	4.40 (112)	6.75 (172)	2.16 (55)	50	5.7 (2.5)	6.4 (2.9)
	4000	5.50 (140)	6.75 (172)	0.88 (22)	0.75 (19)	1.07 (27)	1.25 (32)	4.40 (112)	6.75 (172)	2.16 (55)	50	5.7 (2.5)	6.4 (2.9)
	6000	5.50 (140)	6.75 (172)	0.88 (22)	0.75 (19)	1.07 (27)	1.50 (38)	4.40 (112)	6.75 (172)	2.16 (55)	50	8.6 (3.9)	9.2 (4.1)
1 1/2 (40)	2000	7.40 (188)	8.54 (217)	1.50 (38)	1.50 (38)	1.92 (49)	2.50 (64)	5.62 (143)	11.00 (279)	3.52 (89)	260	21.9 (9.9)	25.7 (11.6)
	3000	7.40 (188)	8.54 (217)	1.50 (38)	1.50 (38)	1.92 (49)	2.50 (64)	5.62 (143)	11.00 (279)	3.52 (89)	260	21.9 (9.9)	25.7 (11.6)
	4000	7.40 (188)	8.54 (217)	1.50 (38)	1.50 (38)	1.92 (49)	2.50 (64)	5.62 (143)	11.00 (279)	3.52 (89)	260	21.9 (9.9)	25.7 (11.6)
	6000	7.40 (188)	8.54 (217)	1.50 (38)	1.50 (38)	1.92 (49)	2.50 (64)	5.62 (143)	11.00 (279)	3.52 (89)	260	21.9 (9.9)	25.7 (11.6)
2 (50)	2000	9.50 (241)	12.75 (324)	2.00 (51)	2.00 (51)	2.41 (61)	2.53 (64)	6.96 (177)	11.88 (302)	4.83 (123)	480	38.3 (17)	46.5 (21.0)
	3000	9.50 (241)	12.75 (324)	2.00 (51)	2.00 (51)	2.41 (61)	2.53 (64)	6.96 (177)	11.88 (302)	4.83 (123)	480	38.3 (17)	46.5 (21.0)
	4000	9.50 (241)	12.75 (324)	2.00 (51)	2.00 (51)	2.41 (61)	2.53 (64)	6.96 (177)	11.88 (302)	4.83 (123)	480	38.3 (17)	46.5 (21.0)
	6000	9.50 (241)	12.75 (324)	2.00 (51)	2.00 (51)	2.41 (61)	2.53 (64)	6.96 (177)	11.88 (302)	4.83 (123)	480	38.3 (17)	46.5 (21.0)

* 4.69 in. (119.1 mm) for Stainless Steel valves.

NOTE: " A " dimension to be within ± 0.062 in. (1.5 mm).

FORGED STEEL FLOATING BALL VALVES MODEL T3 REDUCED PORT - SOCKET WELD & THREADED x SOCKET WELD

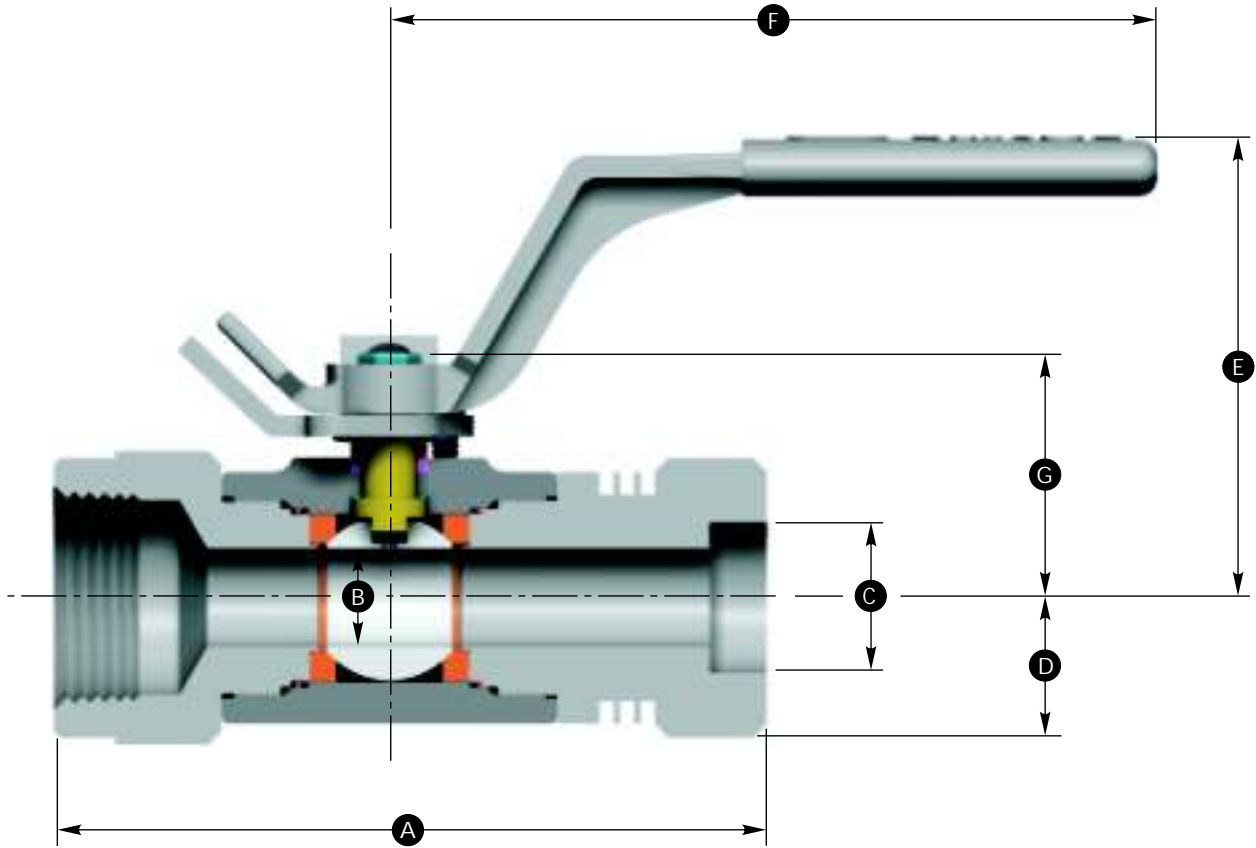

DIMENSIONS

SIZE	WOG	A		B	C		D	E	F	G	C _v	WEIGHT lb. (kg)	
in. (mm)		FNPT x SW	SW		FNPT x SW	SW						FNPT x SW	SW
3/4 (20)	2000	5.56 (141)	6.75 (172)	0.50 (13)	0.75 (19)	1.07 (27)	1.19 (30)	3.29 (83)	4.82 (122)	1.73 (44)	14	3.5 (1.5)	4.4 (1.9)
	3000	5.56 (141)	6.75 (172)	0.50 (13)	0.75 (19)	1.07 (27)	1.19 (30)	3.29 (83)	4.82 (122)	1.73 (44)	14	3.5 (1.5)	4.4 (1.9)
	4000	5.56 (141)	6.75 (172)	0.50 (13)	0.75 (19)	1.07 (27)	1.19 (30)	3.29 (83)	4.82 (122)	1.73 (44)	14	3.5 (1.5)	4.4 (1.9)
	6000	5.56 (141)	6.75 (172)	0.50 (13)	0.75 (19)	1.07 (27)	1.19 (30)	3.29 (83)	4.82 (122)	1.73 (44)	14	3.5 (1.5)	4.4 (1.9)
1 (25)	2000	5.50 (140)*	6.75 (172)	0.88 (22)	1.00 (25)	1.34 (34)	1.25 (32)	4.40 (112)	6.75 (172)	2.16 (55)	35	5.4 (2.4)	6.2 (2.8)
	3000	5.50 (140)*	6.75 (172)	0.88 (22)	1.00 (25)	1.34 (34)	1.25 (32)	4.40 (112)	6.75 (172)	2.16 (55)	35	5.4 (2.4)	6.2 (2.8)
	4000	5.50 (140)*	6.75 (172)	0.88 (22)	1.00 (25)	1.34 (34)	1.25 (32)	4.40 (112)	6.75 (172)	2.16 (55)	35	5.4 (2.4)	6.2 (2.8)
	6000	6.00 (152)	6.75 (172)	0.88 (22)	1.00 (25)	1.34 (34)	1.50 (38)	4.40 (112)	6.75 (172)	2.16 (55)	35	8.3 (3.7)	9.0 (4.0)
2 (50)	2000	7.40 (188)	8.55 (217)	1.50 (38)	2.00 (51)	2.42 (62)	2.50 (64)	5.62 (143)	11.00 (280)	3.52 (90)	100	22.5 (10.2)	26.0 (11.7)
	3000	7.40 (188)	8.55 (217)	1.50 (38)	2.00 (51)	2.42 (62)	2.50 (64)	5.62 (143)	11.00 (280)	3.52 (90)	100	22.5 (10.2)	26.0 (11.7)
	4000	7.40 (188)	8.55 (217)	1.50 (38)	2.00 (51)	2.42 (62)	2.50 (64)	5.62 (143)	11.00 (280)	3.52 (90)	100	22.5 (10.2)	26.0 (11.7)
	6000	7.90 (201)	8.55 (217)	1.50 (38)	2.00 (51)	2.42 (62)	2.50 (64)	5.62 (143)	11.00 (280)	3.52 (90)	100	22.5 (10.2)	26.0 (11.7)
3 (80)	2000	11.38 (289)	12.75 (324)	2.00 (51)	3.00 (76)	3.55 (90)	2.53 (64)	6.96 (177)	11.88 (302)	4.83 (123)	420	49.0 (22.2)	60.0 (27.2)
	3000	11.38 (289)	12.75 (324)	2.00 (51)	3.00 (76)	3.55 (90)	2.53 (64)	6.96 (177)	11.88 (302)	4.83 (123)	420	49.0 (22.2)	60.0 (27.2)
	4000	11.38 (289)	12.75 (324)	2.00 (51)	3.00 (76)	3.55 (90)	2.53 (64)	6.96 (177)	11.88 (302)	4.83 (123)	420	49.0 (22.2)	60.0 (27.2)

* 6.00 in. (152 mm) for Stainless Steel valves.

NOTE: " A " dimension to be within ± 0.062 in. (1.5 mm).

FORGED STEEL FLOATING BALL VALVES MODEL T3 FULL PORT - FLANGED

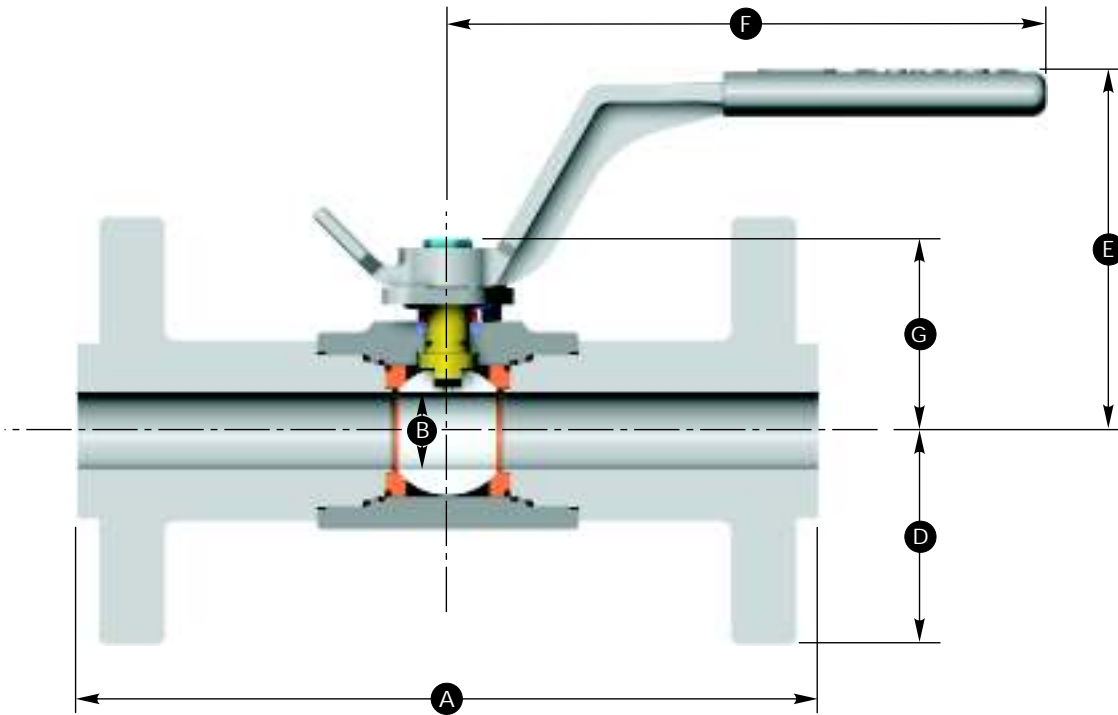

DIMENSIONS

SIZE in. (mm)	ASME CLASS	(PN)	A		B	D	E	F	G	C _v	WEIGHT lb. (kg)
			RF	RTJ							
1/2 (15)	150	(20)	4.25 (108)	-	0.50 (13)	1.75 (45)	3.29 (83)	4.82 (122)	1.73 (44)	26	4.0 (1.8)
	300	(50)	5.50 (140)	5.94 (151)	0.50 (13)	1.87 (48)	3.29 (83)	4.82 (122)	1.73 (44)	26	4.4 (1.9)
	600	(100)	6.50 (165)	6.50 (165)	0.50 (13)	1.87 (48)	3.29 (83)	4.82 (122)	1.73 (44)	26	5.5 (2.4)
	900/1500	(150/250)	8.50 (216)	8.50 (216)	0.50 (13)	2.37 (60)	5.73 (146)	8.00 (203)	1.73 (44)	26	11.0 (4.9)
	2500	(420)	10.37 (264)	10.37 (264)	0.50 (13)	2.63 (67)	5.73 (146)	8.00 (203)	1.73 (44)	26	17.5 (7.9)
3/4 (20)	150	(20)	*6.00 (152)	-	0.88 (22)	1.94 (49)	4.40 (112)	6.75 (172)	2.16 (55)	50	10.3 (4.6)
	300	(50)	6.00 (152)	6.50 (165)	0.88 (22)	2.31 (59)	4.40 (112)	6.75 (172)	2.16 (55)	50	10.3 (4.6)
	600	(100)	7.50 (191)	7.50 (191)	0.88 (22)	2.31 (59)	4.40 (112)	6.75 (172)	2.16 (55)	50	13.3 (6.0)
	900/1500	(150/250)	9.00 (229)	9.00 (229)	0.88 (22)	2.56 (65)	4.40 (112)	6.75 (172)	2.16 (55)	50	16.3 (7.3)
	2500	(420)	10.75 (273)	10.75 (273)	0.88 (22)	2.75 (70)	6.20 (158)	8.12 (206)	2.16 (55)	50	22.8 (10.3)
1 1/2 (40)	150	(20)	6.50 (165)	7.00 (178)	1.50 (38)	2.50 (64)	5.62 (143)	11.00 (279)	3.52 (89)	260	21.0 (9.5)
	300	(50)	7.50 (191)	8.00 (203)	1.50 (38)	3.06 (78)	5.62 (143)	11.00 (279)	3.52 (89)	260	29.0 (13.1)
	600	(100)	9.50 (241)	9.50 (241)	1.50 (38)	3.06 (78)	5.62 (143)	11.00 (279)	3.52 (89)	260	32.5 (14.7)
	900/1500	(150/250)	12.00 (305)	12.00 (305)	1.50 (38)	3.50 (89)	5.62 (143)	11.00 (279)	3.52 (89)	260	46.0 (20.8)
	2500	(420)	15.12 (384)	15.25 (387)	1.50 (38)	4.00 (102)	5.62 (143)	11.00 (279)	3.52 (89)	260	74.0 (33.5)
2 (50)	150	(20)	7.00 (178)	7.50 (191)	2.00 (51)	3.00 (76)	6.96 (177)	11.88 (302)	4.83 (123)	480	36.2 (16.4)
	300	(50)	8.50 (216)	9.12 (232)	2.00 (51)	3.25 (83)	6.96 (177)	11.88 (302)	4.83 (123)	480	43.3 (19.6)
	600	(100)	11.50 (292)	11.62 (295)	2.00 (51)	3.25 (83)	6.96 (177)	11.88 (302)	4.83 (123)	480	51.5 (23.3)
	900/1500	(150/250)	14.50 (368)	14.62 (371)	2.00 (51)	4.25 (108)	6.96 (177)	11.88 (302)	4.83 (123)	480	81.0 (36.7)
	2500	(420)	17.75 (451)	17.87 (454)	2.00 (51)	4.62 (118)	6.96 (177)	11.88 (302)	4.83 (123)	480	121.0 (54.8)
3 (80)	150	(20)	8.00 (203)	8.50 (216)	3.00 (76)	3.75 (95)	8.26 (210)	23.89 (607)	5.37 (137)	1300	58.0 (26.3)
	300	(50)	11.12 (282)	11.75 (299)	3.00 (76)	4.12 (105)	8.26 (210)	23.89 (607)	5.37 (137)	1300	77.5 (35.1)

NOTE: " A " dimension to be within ± 0.062 in. (1.5 mm).

* Non-Standard Length.

FORGED STEEL FLOATING BALL VALVES MODEL T3 REDUCED PORT - FLANGED

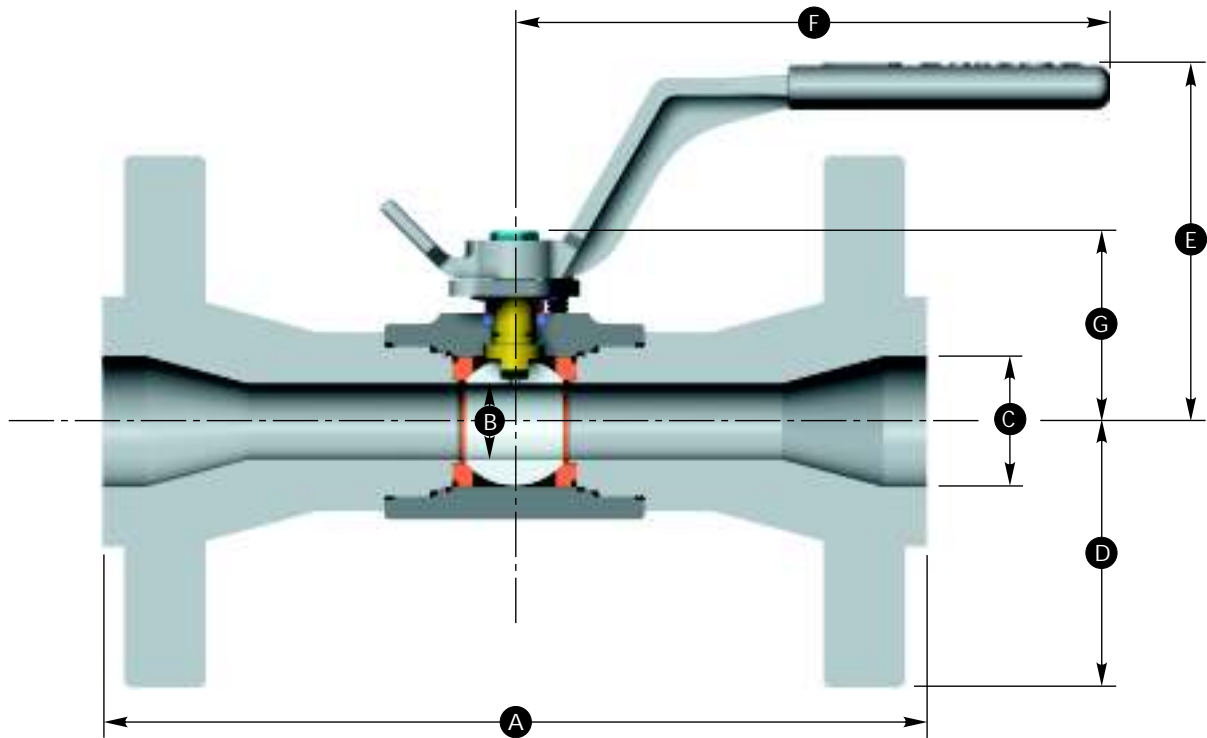

DIMENSIONS

SIZE in. (mm)	ASME CLASS	PN	A		B	C	D	E	F	G	C _v	WEIGHT lb. (kg)	
			RF	RTJ									
3/4 (20)	150	(20)	4.63 (118)	-	0.50 (13)	0.75 (19)	1.94 (49)	3.29 (83)	4.82 (122)	1.73 (44)	14	5.0 (2.2)	
	300	(50)	6.00 (152)	6.50 (165)	0.50 (13)	0.75 (19)	2.31 (59)	3.29 (83)	4.82 (122)	1.73 (44)	14	7.0 (3.1)	
	600	(100)	7.50 (191)	7.50 (191)	0.50 (13)	0.75 (19)	2.31 (59)	3.29 (83)	4.82 (122)	1.73 (44)	14	9.0 (4.0)	
900/1500 (150/250)	900/1500	(150/250)	9.00 (229)	9.00 (229)	0.50 (13)	0.75 (19)	2.56 (65)	5.73 (146)	8.00 (203)	1.73 (44)	14	14.0 (6.3)	
	2500	(420)	10.75 (273)	10.75 (273)	0.50 (13)	0.75 (19)	2.75 (70)	5.73 (146)	8.00 (203)	1.73 (44)	14	20.5 (9.2)	
	1 (25)	150	(20)	5.00 (127)	5.50 (140)	0.88 (22)	1.00 (25)	2.12 (54)	4.40 (112)	6.75 (172)	2.16 (55)	35	8.0 (3.6)
300	300	(50)	6.50 (165)	7.00 (178)	0.88 (22)	1.00 (25)	2.44 (62)	4.40 (112)	6.75 (172)	2.16 (55)	35	11.5 (5.2)	
	600	(100)	8.50 (216)	8.50 (216)	0.88 (22)	1.00 (25)	2.44 (62)	4.40 (112)	6.75 (172)	2.16 (55)	35	13.8 (6.2)	
	900/1500 (150/250)	900/1500	(150/250)	10.00 (254)	10.00 (254)	0.88 (22)	1.00 (25)	2.94 (75)	4.40 (112)	6.75 (172)	2.16 (55)	35	23.0 (10.4)
2500	2500	(420)	12.12 (308)	12.12 (308)	0.88 (22)	1.00 (25)	3.13 (79)	6.20 (158)	8.12 (206)	2.16 (55)	35	32.0 (14.5)	
	2 (50)	150	(20)	7.00 (178)	7.50 (191)	1.50 (38)	2.00 (51)	3.00 (76)	5.62 (143)	11.00 (279)	3.52 (89)	100	27.0 (12.2)
	300	(50)	8.50 (216)	9.12 (232)	1.50 (38)	2.00 (51)	3.25 (83)	5.62 (143)	11.00 (279)	3.52 (89)	100	32.0 (14.5)	
600	600	(100)	11.50 (292)	11.62 (295)	1.50 (38)	2.00 (51)	3.25 (83)	5.62 (143)	11.00 (279)	3.52 (89)	100	38.0 (17.2)	
	900/1500 (150/250)	900/1500	(150/250)	14.50 (368)	14.62 (371)	1.50 (38)	2.00 (51)	4.25 (108)	5.62 (143)	11.00 (279)	3.52 (89)	100	72.0 (32.6)
	2500	(420)	17.75 (451)	17.87 (454)	1.50 (38)	2.00 (51)	4.62 (118)	5.62 (143)	11.00 (279)	3.52 (89)	100	107.5 (48.7)	
3 (80)	150	(20)	8.00 (203)	8.50 (216)	2.00 (51)	3.00 (76)	3.75 (95)	6.96 (177)	11.88 (302)	4.83 (123)	420	50.0 (22.6)	
	300	(50)	11.12 (282)	11.75 (299)	2.00 (51)	3.00 (76)	4.12 (105)	6.96 (177)	11.88 (302)	4.83 (123)	420	63.2 (28.6)	
	600	(100)	14.00 (356)	14.12 (359)	2.00 (51)	3.00 (76)	4.12 (105)	6.96 (177)	11.88 (302)	4.83 (123)	420	76.0 (34.4)	
900	900	(150)	15.00 (381)	15.12 (384)	2.00 (51)	3.00 (76)	4.75 (121)	6.96 (177)	11.88 (302)	4.83 (123)	420	97.0 (43.9)	
	1500	(250)	18.50 (470)	18.62 (473)	2.00 (51)	3.00 (76)	5.25 (133)	6.96 (177)	11.88 (302)	4.83 (123)	420	134.0 (60.7)	
	2500	(420)	22.75 (578)	23.00 (584)	2.00 (51)	3.00 (76)	6.00 (152)	7.77 (197)	23.89 (607)	4.83 (123)	420	223.0 (101.1)	
4 (100)	150	(20)	9.00 (229)	9.50 (241)	3.00 (76)	4.00 (102)	4.50 (114)	8.26 (210)	23.89 (607)	5.37 (137)	770	72.5 (32.8)	
	300	(50)	12.00 (305)	12.63 (321)	3.00 (76)	4.00 (102)	5.00 (127)	8.26 (210)	23.89 (607)	5.37 (137)	770	99.0 (44.9)	

NOTE: " A " dimension to be within ± 0.062 in. (1.5 mm).

FORGED STEEL FLOATING BALL VALVES STANDARD FEATURES

MODEL B3

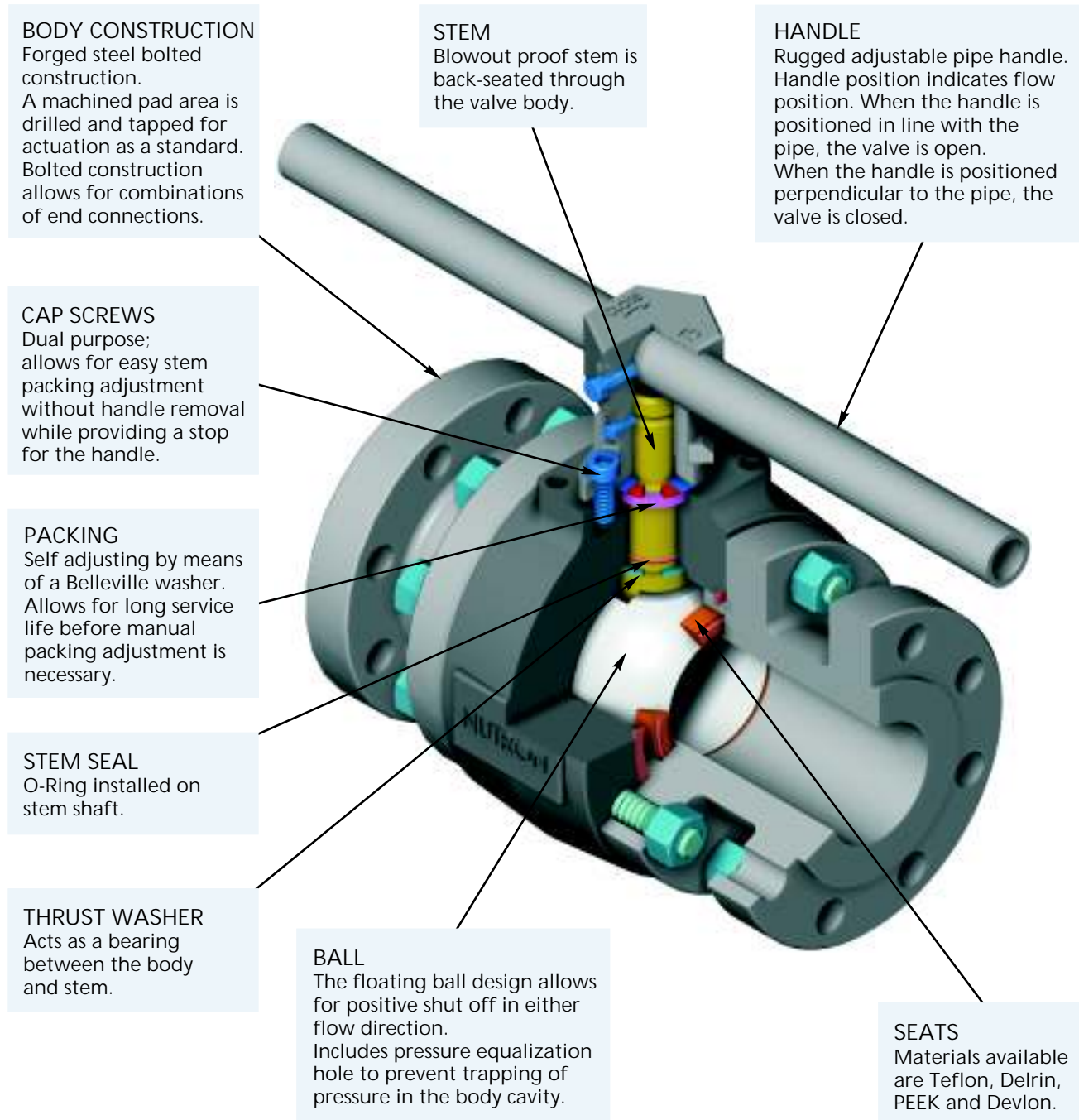

FORGED STEEL FLOATING BALL VALVES MODEL B3 SIZES AVAILABLE

ASME CLASS (PN)		150 (20)	300 (50)	600 (100)	900 (150)	1500 (250)
Full Port	in. (mm)	2 thru 4 (50 thru 100)	2 thru 4 (50 thru 100)	1 1/2 thru 3 (40 thru 80)	1 1/2 thru 3 (40 thru 80)	1 1/2 thru 3 (40 thru 80)
Reduced Port		3 thru 6 (80 thru 150)	3 thru 6 (80 thru 150)	2 thru 4 (50 thru 100)	2 thru 4 (50 thru 100)	2 thru 4 (50 thru 100)
WOG (psi)				2000		4000
Full Port	in. (mm)			3 (80)		3 (80)
Reduced Port				4 (100)		

ORDERING INFORMATION

How to develop typical figure numbers without options:

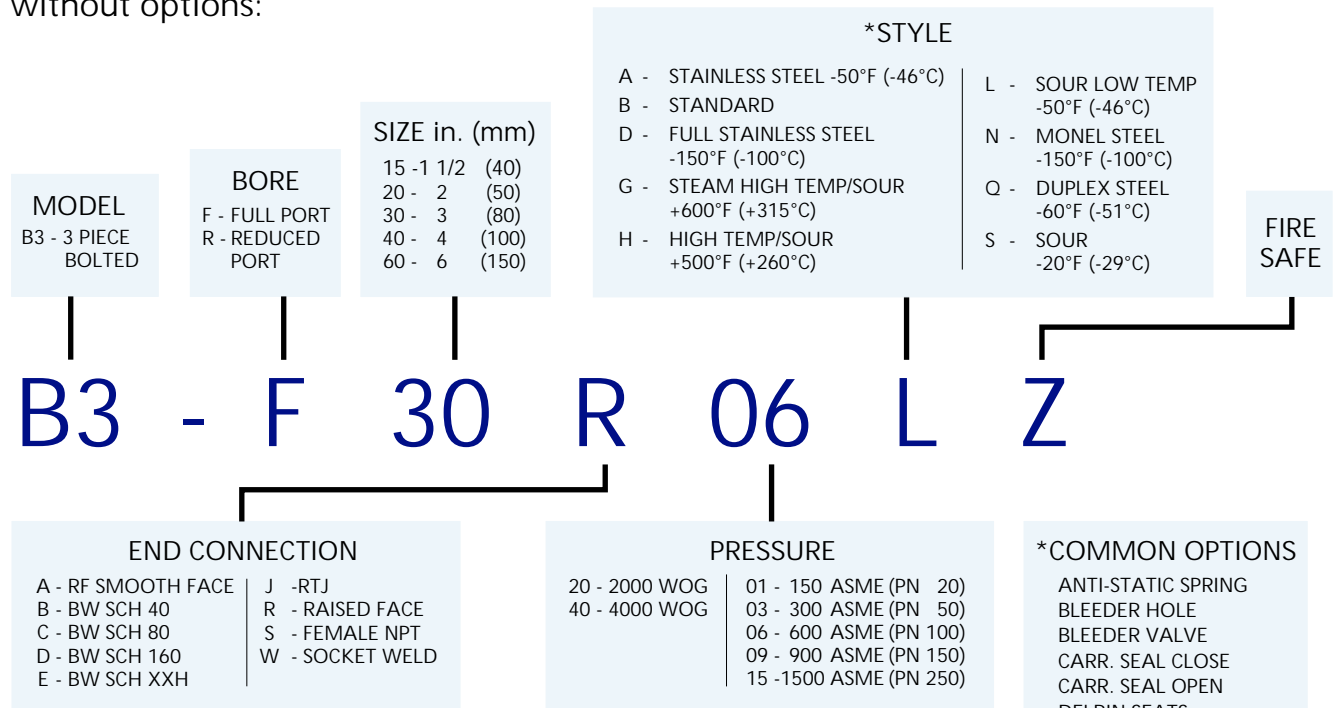

Examples:

B3-F30R06LZ = Model B3, Full Port, 3 in. (80 mm), Raised Face Flanges, 600 ASME (PN 100), Sour Low Temp Valve, Fire Safe.

* Consult Cameron, Valves & Measurement Sales Department for detailed valve style descriptions, full range of options, materials, actuation packages or for a particular special valve service application.

Cameron reserves the right to substitute materials listed on the following pages with alternate materials for the designated service.

FORGED STEEL FLOATING BALL VALVES
MODEL B3 THREADED END CONNECTIONS

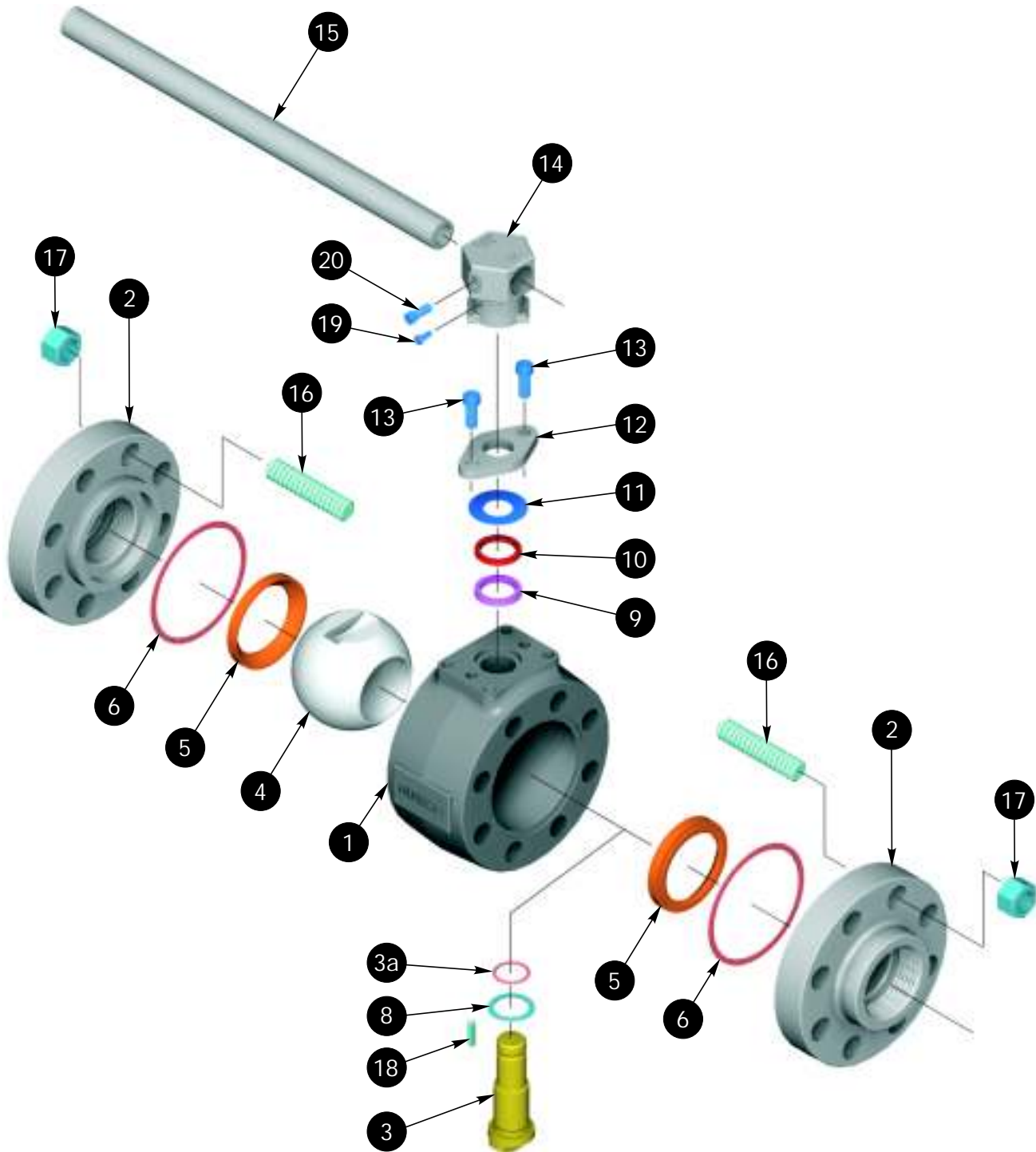

FORGED STEEL FLOATING BALL VALVES MODEL B3 MATERIALS LIST - THREADED END CONNECTIONS

ITEM	PART	WORKING PRESSURE	STANDARD -20°F (-29°C)	SOUR -20°F (-29°C)
1	Body	All	ASTM A105	ASTM A105
2	End Caps	All	ASTM A350 LF2	ASTM A350 LF2
□ 3	Stem	All	ASTM A322 Gr. 4130, Plated	ASTM A564 17-4PH
□ ! 3a	Stem O-Ring	All	HSN	HSN
□ 4	Ball	All	Carbon Steel, Chrome Plated	ASTM A351 Gr. CF8M
□ ! 5	Seats	2000 4000	Teflon Delrin	Teflon Delrin
□ ! 6	Body Seals	All	Spiral Wound Gasket	Spiral Wound Gasket
□ ! 8	Thrust Washer	2000 4000	Teflon Delrin	Teflon Delrin
□ ! 9	Packing	2000/4000	Graphite/Teflon	Graphite/Teflon
10	Packing Follower	All	Carbon Steel, Plated	Stainless Steel
11	Belleville Washer	All	Carbon Steel	Stainless Steel
12	Gland Flange	All	Carbon Steel, Plated	Carbon Steel, Plated
13	Cap Screws	All	Carbon Steel	Stainless Steel
14	Handle Nut	All	Carbon Steel	Carbon Steel
15	Pipe	All	Carbon Steel	Carbon Steel
16	Studs	All	ASTM A193 B7	ASTM A193 B7M
17	Nuts	All	ASTM A194 2H	ASTM A194 2HM
18	Key	All	Carbon Steel	Carbon Steel
19	Screw	All	Carbon Steel, Plated	Carbon Steel, Plated
20	Screw	All	Carbon Steel, Plated	Carbon Steel, Plated
ITEM	PART	WORKING PRESSURE	SOUR & LOW TEMP -50°F (-46°C)	STAINLESS STEEL -50°F (-46°C)
1	Body	All	ASTM A350 LF2	ASTM A479 TYPE 316
2	End Caps	All	ASTM A350 LF2	ASTM A479 TYPE 316
□ 3	Stem	All	ASTM A564 17-4PH	ASTM A564 17-4PH with Nitriding
□ ! 3a	Stem O-Ring	All	HSN	HSN
□ 4	Ball	All	ASTM A351 Gr. CF8M	ASTM A351 Gr. CF8M
□ ! 5	Seats	2000 4000	Teflon Delrin	Teflon PEEK
□ ! 6	Body Seals	All	Spiral Wound Gasket	Spiral Wound Gasket
□ ! 8	Thrust Washer	2000 4000	Teflon Delrin	Teflon PEEK
□ ! 9	Packing	2000/4000	Graphite/Teflon	Graphite/Teflon
10	Packing Follower	All	Stainless Steel	Stainless Steel
11	Belleville Washer	All	Stainless Steel	Stainless Steel
12	Gland Flange	All	Carbon Steel, Plated	Carbon Steel, Plated
13	Cap Screws	All	Stainless Steel	Stainless Steel
14	Handle Nut	All	Carbon Steel	Carbon Steel
15	Pipe	All	Carbon Steel	Carbon Steel
16	Studs	All	ASTM A320 L7M	ASTM A320 L7M, Coated
17	Nuts	All	ASTM A194 L7M	ASTM A194 L7M, Coated
18	Key	All	Carbon Steel	Carbon Steel
19	Screw	All	Carbon Steel, Plated	Carbon Steel, Plated
20	Screw	All	Carbon Steel, Plated	Carbon Steel, Plated

□ Major repair kit.

! Minor repair kit.

FORGED STEEL FLOATING BALL VALVES
 MODEL B3 FLANGED END CONNECTIONS
 3 in. (80 mm) FULL PORT & 4 in. (100 mm) REDUCED PORT
 ASME CLASS 600, 900 & 1500 (PN 100, 150 & 250)

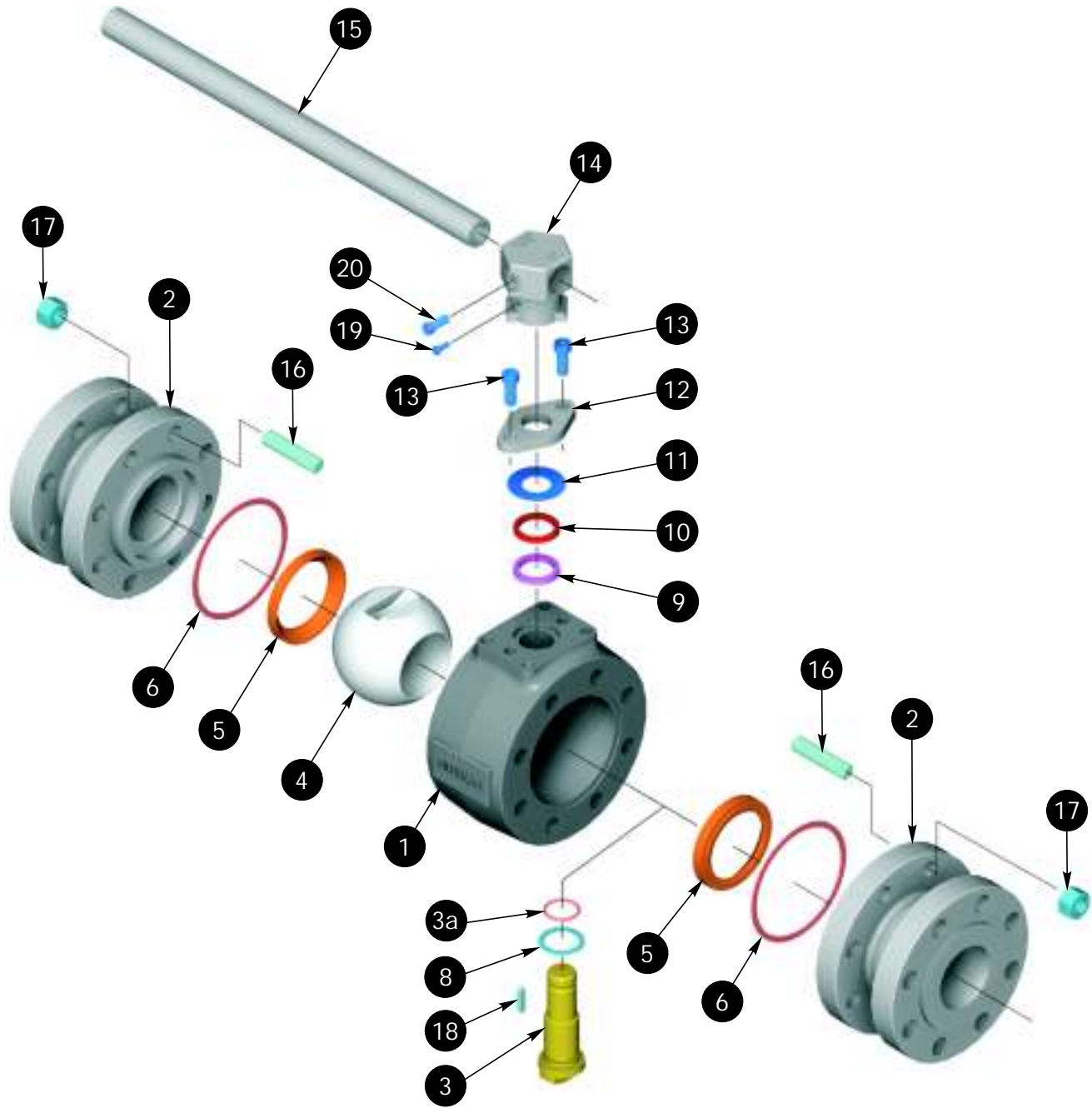

FORGED STEEL FLOATING BALL VALVES MODEL B3 MATERIALS LIST - FLANGED END CONNECTIONS

3 in. (80 mm) FULL PORT & 4 in. (100 mm) REDUCED PORT, ASME CLASS 600, 900 & 1500 (PN 100, 150 & 250)

ITEM	PART	ASME CLASS	STANDARD -20°F (-29°C)	SOUR -20°F (-29°C)
1	Body	All	ASTM A105	ASTM A105
2	End Caps	600, 900 & 1500	ASTM A105	ASTM A105
□ 3 □ ! 3a	Stem Stem O-Ring	All All	ASTM A322 Gr. 4130, Plated HSN	ASTM A564 17-4PH HSN
□ 4	Ball	All	ASTM A675 CHR. PL.	ASTM A351 Gr. CF8M
□ ! 5	Seats	600 900 & 1500	Teflon Delrin	Teflon Delrin
□ ! 6	Body Seals	All	Spiral Wound Gasket	Spiral Wound Gasket
□ ! 8	Thrust Washer	600 900 & 1500	Teflon Delrin	Teflon Delrin
□ ! 9	Packing	All	Graphite	Graphite
10	Packing Follower	All	Carbon Steel, Plated	Stainless Steel
11	Belleville Washer	All	Carbon Steel	Stainless Steel
12	Gland Flange	All	Carbon Steel, Plated	Carbon Steel, Plated
13	Cap Screws	All	Carbon Steel	Stainless Steel
14	Handle Nut	All	Carbon Steel	Carbon Steel
15	Pipe	All	Carbon Steel	Carbon Steel
16	Studs	All	ASTM A193 B7	ASTM A193 B7M
17	Nuts	All	ASTM A194 2H	ASTM A194 2HM
18	Key	All	Carbon Steel	Carbon Steel
19	Screw	All	Carbon Steel, Plated	Carbon Steel, Plated
20	Screw	All	Carbon Steel, Plated	Carbon Steel, Plated

ITEM	PART	ASME CLASS	SOUR & LOW TEMP -50°F (-46°C)	STAINLESS STEEL -50°F (-46°C)
1	Body	All	ASTM A350 LF2	ASTM A479 TYPE 316
2	End Caps	All	ASTM A350 LF2	ASTM A479 TYPE 316
□ 3 □ ! 3a	Stem Stem O-Ring	All All	ASTM A564 17-4PH HSN	ASTM A564 17-4PH with Nitriding HSN
□ 4	Ball	All	ASTM A351 Gr. CF8M	ASTM A351 Gr. CF8M
□ ! 5	Seats	600 900 & 1500	Teflon Delrin	Teflon PEEK
□ ! 6	Body Seals	All	Spiral Wound Gasket	Spiral Wound Gasket
□ ! 8	Thrust Washer	600 900 & 1500	Teflon Delrin	Teflon PEEK
□ ! 9	Packing	All	Graphite	Graphite
10	Packing Follower	All	Stainless Steel	Stainless Steel
11	Belleville Washer	All	Stainless Steel	Stainless Steel
12	Gland Flange	All	Carbon Steel, Plated	Carbon Steel, Plated
13	Cap Screws	All	Stainless Steel	Stainless Steel
14	Handle Nut	All	Carbon Steel	Carbon Steel
15	Pipe	All	Carbon Steel	Carbon Steel
16	Studs	All	ASTM A320 L7M	ASTM A320 L7M, Coated
17	Nuts	All	ASTM A194 L7M	ASTM A194 L7M, Coated
18	Key	All	Carbon Steel	Carbon Steel
19	Screw	All	Carbon Steel, Plated	Carbon Steel, Plated
20	Screw	All	Carbon Steel, Plated	Carbon Steel, Plated

□ Major repair kit.
! Minor repair kit.

Note: Fire safe trim offered as standard whenever possible.
Consult Cameron, Valves & Measurement Sales Department for fire safe trim.

FORGED STEEL FLOATING BALL VALVES
 MODEL B3 - 4 in. (100 mm) FULL PORT / 6 in. (150 mm) REDUCED PORT
 ASME CLASS 150 & 300 (PN 20 & 50)

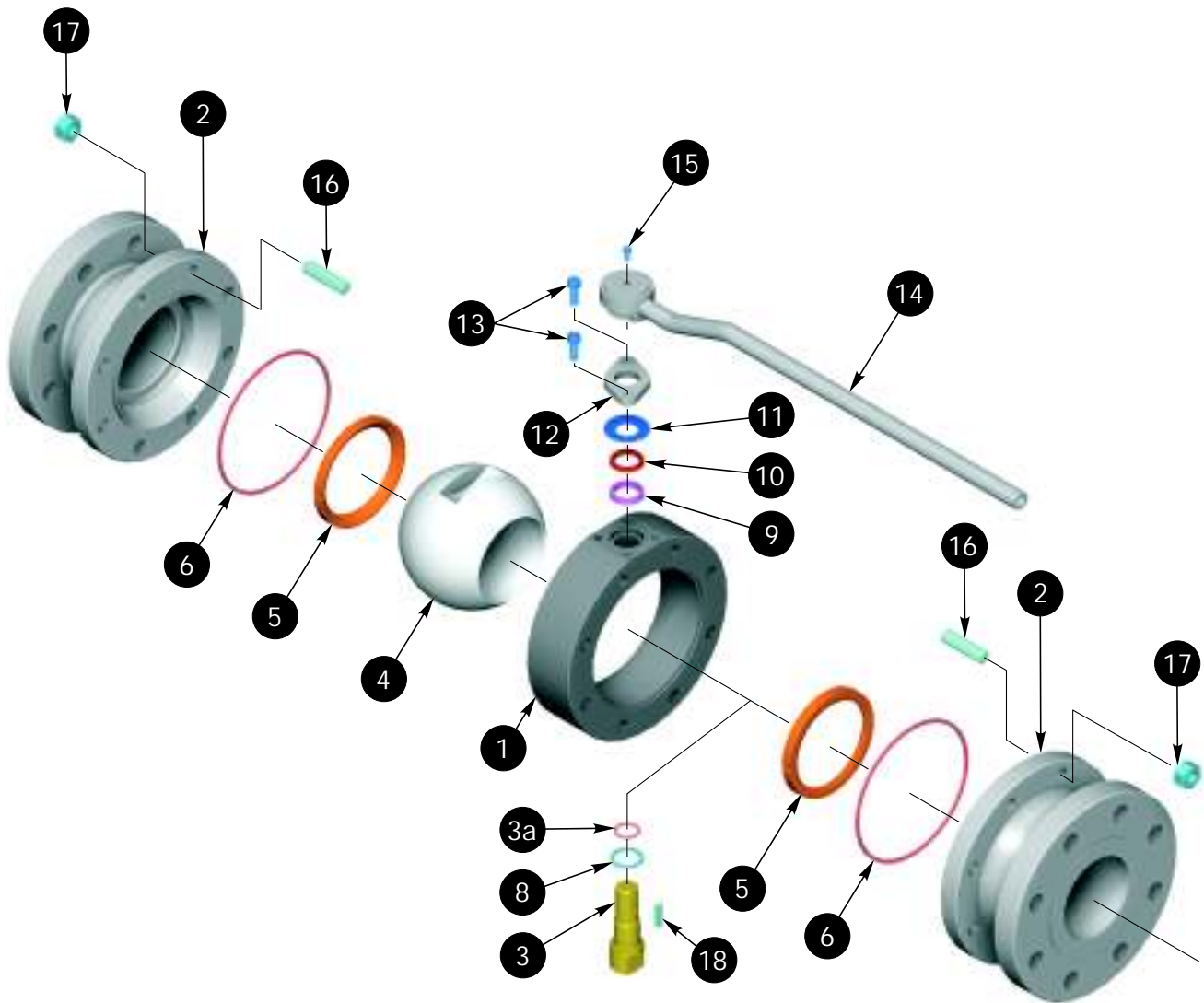

FORGED STEEL FLOATING BALL VALVES MODEL B3 MATERIALS LIST

4 in. (100 mm) FULL PORT & 6 in. (150 mm) REDUCED PORT
ASME CLASS 150 & 300 (PN 20 & 50)

ITEM	PART	SOUR -20°F (-29°C)	SOUR & LOW TEMP -20°F (-29°C)
1	Body	ASTM A105	ASTM A350 LF2
2	End Caps	ASTM A350 LF2	ASTM A350 LF2
□ 3	Stem	ASTM A564 17-4PH	ASTM A564 17-4PH
□ ! 3a	Stem O-Ring	HSN	HSN
□ 4	Ball	ASTM A351 Gr. CF8M	ASTM A351 Gr. CF8M
□ ! 5	Seats	Teflon	Teflon
□ ! 6	Body O-Rings	Viton	Viton
□ ! 8	Thrust Washer	Teflon	Teflon
□ ! 9	Packing	Graphite	Graphite
10	Packing Follower	Stainless Steel	Stainless Steel
11	Belleville Washer	Stainless Steel	Stainless Steel
12	Gland Flange	Carbon Steel, Plated	Carbon Steel, Plated
13	Cap Screws	Stainless Steel	Stainless Steel
14	Handle	Carbon Steel	Carbon Steel
15	Cap Screw, Hex Head	Carbon Steel	Carbon Steel
16	Studs	ASTM A193 B7M	ASTM A320 L7M
17	Nuts	ASTM A194 2HM	ASTM A194 L7M
18	Key	Carbon Steel	Carbon Steel

ITEM	PART	STAINLESS STEEL -50°F (-46°C)
1	Body	ASTM A479 TYPE 316
2	End Caps	ASTM A479 TYPE 316
□ 3	Stem	ASTM A564 17-4PH with Nitriding
□ ! 3a	Stem O-Ring	HSN
□ 4	Ball	ASTM A351 Gr. CF8M
□ ! 5	Seats	Teflon
□ ! 6	Body O-Rings	Teflon
□ ! 8	Thrust Washer	Teflon
□ ! 9	Packing	Graphite
10	Packing Follower	Stainless Steel
11	Belleville Washer	Stainless Steel
12	Gland Flange	Carbon Steel, Plated
13	Cap Screws	Stainless Steel
14	Handle	Carbon Steel
15	Cap Screw, Hex Head	Carbon Steel
16	Studs	ASTM A320 L7M, Coated
17	Nuts	ASTM A194 L7M, Coated
18	Key	Carbon Steel

□ Major repair kit.

! Minor repair kit.

FORGED STEEL FLOATING BALL VALVES

MODEL B3 THREADED

FULL PORT
3 in. (80 mm)
REDUCED PORT
4 in. (100 mm)

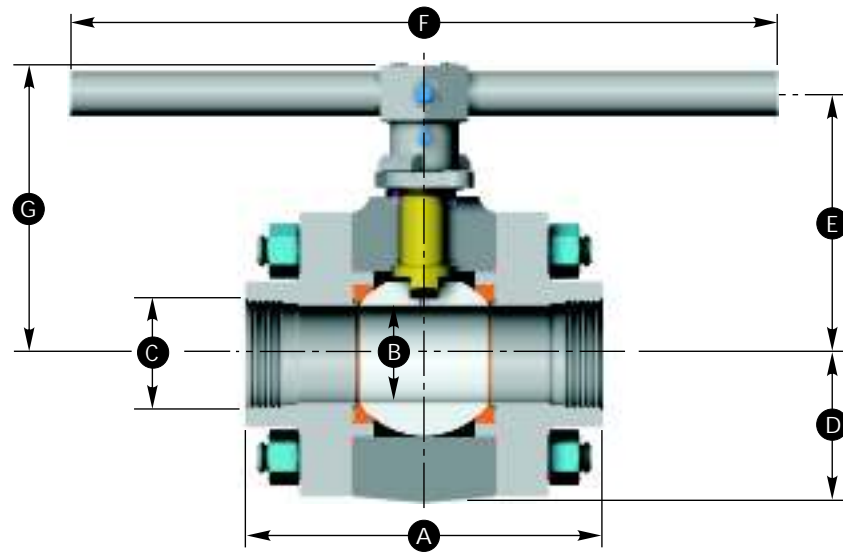

DIMENSIONS

SIZE in. (mm)	WOG	A	B	C	D	E	F	G	C _v	WEIGHT lb. (kg)
3 FP (80 FP)	2000	10.0 (254)	3.0 (76)	3.0 (76)	4.45 (113)	7.55 (192)	22.0 (559)	7.55 (192)	1300	131.0 (59.4)
	4000	10.0 (254)	3.0 (76)	3.0 (76)	4.45 (113)	7.55 (192)	22.0 (559)	7.55 (192)	1300	131.0 (59.4)
4 RP (100 RP)	2000	12.0 (305)	3.0 (76)	4.0 (102)	4.45 (113)	7.55 (192)	22.0 (559)	7.55 (192)	770	145.0 (65.7)

 NOTE: " A " dimension to be within ± 0.062 in. (1.5 mm).

MODEL B3 FLANGED

FULL PORT
3 in. (80 mm)
REDUCED PORT
4 in. (100 mm)

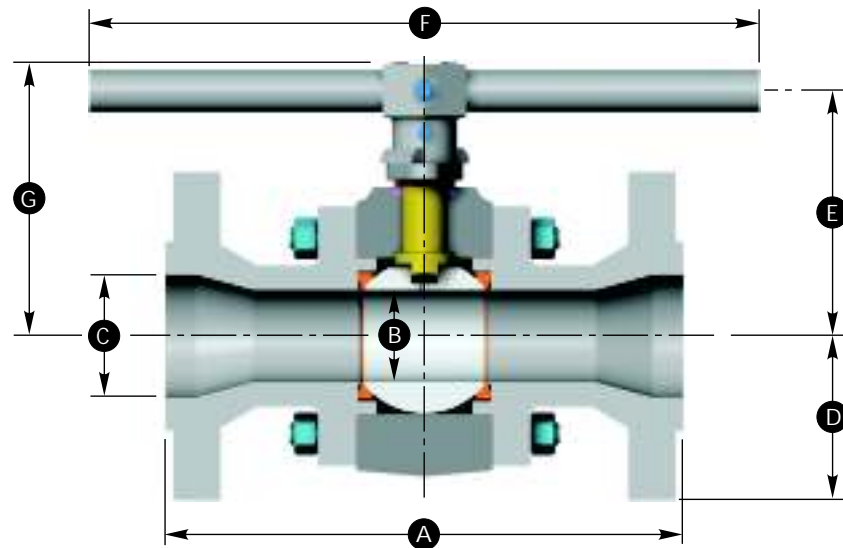

DIMENSIONS

SIZE in. (mm)	ASME CLASS (PN)	A		B	C	D	E	F	G	C _v	WEIGHT lb. (kg)
		RF	RTJ								
3 FP (80 FP)	600 (100)	14.0 (356)	14.12 (359)	3.0 (76)	3.0 (76)	4.12 (105)	7.55 (192)	22.0 (559)	7.55 (192)	1300	161.0 (73.0)
	900 (150)	15.0 (381)	15.12 (384)	3.0 (76)	3.0 (76)	4.75 (121)	7.55 (192)	22.0 (559)	7.55 (192)	1300	191.0 (86.6)
	1500 (250)	18.5 (470)	18.62 (473)	3.0 (76)	3.0 (76)	5.25 (133)	7.55 (192)	22.0 (559)	7.55 (192)	1300	239.0 (108.4)
4 RP (100 RP)	600 (100)	17.0 (432)	17.12 (435)	3.0 (76)	4.0 (102)	5.37 (136)	7.55 (192)	22.0 (559)	7.55 (192)	770	211.0 (95.7)
	900 (150)	18.0 (457)	18.12 (460)	3.0 (76)	4.0 (102)	5.75 (146)	7.55 (192)	22.0 (559)	7.55 (192)	770	242.0 (109.7)
	1500 (250)	21.5 (546)	21.62 (549)	3.0 (76)	4.0 (102)	6.12 (155)	7.55 (192)	22.0 (559)	7.55 (192)	770	292.0 (132.4)

 NOTE: " A " dimension to be within ± 0.062 in. (1.5 mm).

FORGED STEEL FLOATING BALL VALVES

MODEL B3 FLANGED

FULL PORT
4 in. (100 mm)
REDUCED PORT
6 in. (150 mm)

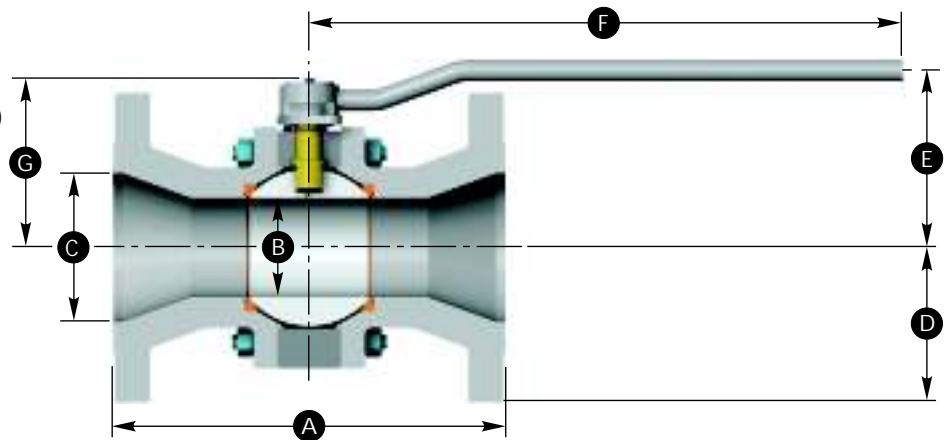

DIMENSIONS

SIZE in. (mm)	ASME CLASS (PN)	A	B	C	D	E	F	G	C _v	WEIGHT lb. (kg)
4 FP (100 FP)	150 (20)	9.00 (229)	4.00 (102)	4.00 (102)	4.88 (124)	7.60 (193)	24.00 (610)	6.65 (169)	2300	101 (45.8)
	300 (50)	12.00 (305)	4.00 (102)	4.00 (102)	5.00 (127)	7.60 (193)	24.00 (610)	6.65 (169)	2300	143 (64.8)
6 RP (150 RP)	150 (20)	10.50 (267)	4.00 (102)	6.00 (152)	5.50 (140)	7.60 (193)	24.00 (610)	6.65 (169)	1800	128 (58.0)
	300 (50)	15.88 (403)	4.00 (102)	6.00 (152)	6.25 (160)	7.60 (193)	24.00 (610)	6.65 (169)	1800	143 (64.8)

MODEL T3 ACTUATOR MOUNTING DIMENSIONS

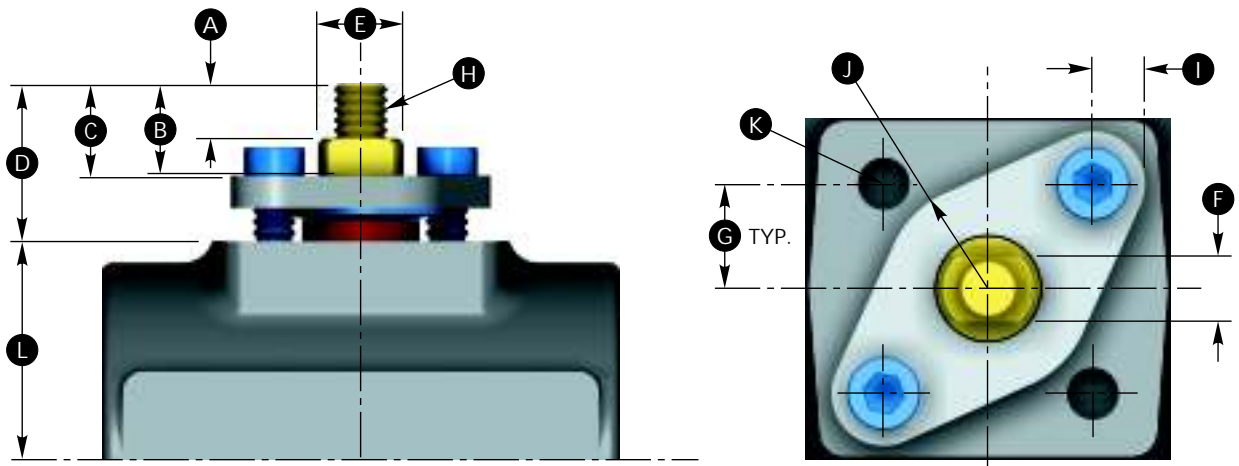

DIMENSIONS

SIZE in. (mm)	A	B	C	D	E	F	G	H	I	J	K	L
1/4 FP (8 FP)	0.300 (7.6)	0.440 (11.1)	0.500 (12.7)	0.725 (18.4)	0.464 (11.8)	0.253 (6.4)	0.468 (11.9)	0.250-20 UNC (6.35-20 UNC)	0.23 (5.8)	0.50 (12.7)	#10-32 UNF-2B x 0.31 DP. (#10-32 UNF-2B x 7.9 DP.)	1.002 (25.5)
3/8 FP (10 FP)	0.300 (7.6)	0.440 (11.1)	0.500 (12.7)	0.725 (18.4)	0.464 (11.8)	0.253 (6.4)	0.468 (11.9)	0.250-20 UNC (6.35-20 UNC)	0.23 (5.8)	0.50 (12.7)	#10-32 UNF-2B x 0.31 DP. (#10-32 UNF-2B x 7.9 DP.)	1.002 (25.5)
1/2 FP / 3/4 RP (15 FP / 20 RP)	0.300 (7.6)	0.440 (11.1)	0.500 (12.7)	0.725 (18.4)	0.464 (11.8)	0.253 (6.4)	0.468 (11.9)	0.250-20 UNC (6.35-20 UNC)	0.23 (5.8)	0.50 (12.7)	#10-32 UNF-2B x 0.31 DP. (#10-32 UNF-2B x 7.9 DP.)	1.002 (25.5)
3/4 FP / 1 RP (20 FP / 25 RP)	0.312 (7.9)	0.515 (13.1)	0.560 (14.2)	0.905 (23.0)	0.496 (12.6)	0.314 (7.9)	0.498 (12.6)	0.312-18 UNC (7.92-18 UNC)	0.25 (6.4)	0.50 (12.7)	0.25-28 UNF-2B x 0.30 DP. (6.35-28 UNF-2B x 7.6 DP.)	1.250 (31.8)
*1 1/2 FP / 2 RP (*40 FP / 50 RP)	0.475 (12.1)	0.826 (21.0)	0.900 (22.9)	1.270 (32.3)	0.749 (19.0)	0.441 (11.2)	0.737 (18.7)	0.438-14 UNC (11.1-14 UNC)	0.40 (10.2)	0.75 (19.1)	0.312-24 UNF-2B x 0.437 DP. (7.92-24 UNF-2B x 11.1 DP.)	2.250 (57.2)
2 FP / 3 RP (50 FP / 80 RP)	0.690 (17.5)	1.180 (30.0)	1.225 (31.1)	1.821 (46.3)	1.000 (25.4)	0.628 (16.0)	0.875 (22.2)	0.625-11 UNC (15.9-11 UNC)	0.41 (10.4)	1.00 (25.4)	0.375-24 UNF-2B x 0.50 DP. (9.53-24 UNF-2B x 12.7 DP.)	3.000 (76.2)
3 FP / 4 RP (80 FP / 100 RP)	0.690 (17.5)	1.180 (30.0)	1.225 (31.1)	1.821 (46.3)	1.000 (25.4)	0.628 (16.0)	0.875 (22.2)	0.625-11 UNC (15.9-11 UNC)	0.41 (10.4)	1.00 (25.4)	0.375-24 UNF-2B x 0.50 DP. (9.53-24 UNF-2B x 12.7 DP.)	3.500 (88.9)

* Applies to B3 1 1/2 in. (40 mm) full port & 2 in. (50 mm) reduced port ASME Class 600, 900 & 1500 valves.

** Applies to B3 2 in. (50 mm) full port & 3 in. (80 mm) reduced port ASME Class 600, 900 & 1500 valves.

*** Applies to B3 3 in. (80 mm) full port & 4 in. (100 mm) reduced port ASME Class 150 & 300 valves.

FORGED STEEL FLOATING BALL VALVES MODEL B3 ACTUATOR MOUNTING DIMENSIONS*

3 in. (80 mm) FULL PORT
4 in. (100 mm) REDUCED PORT

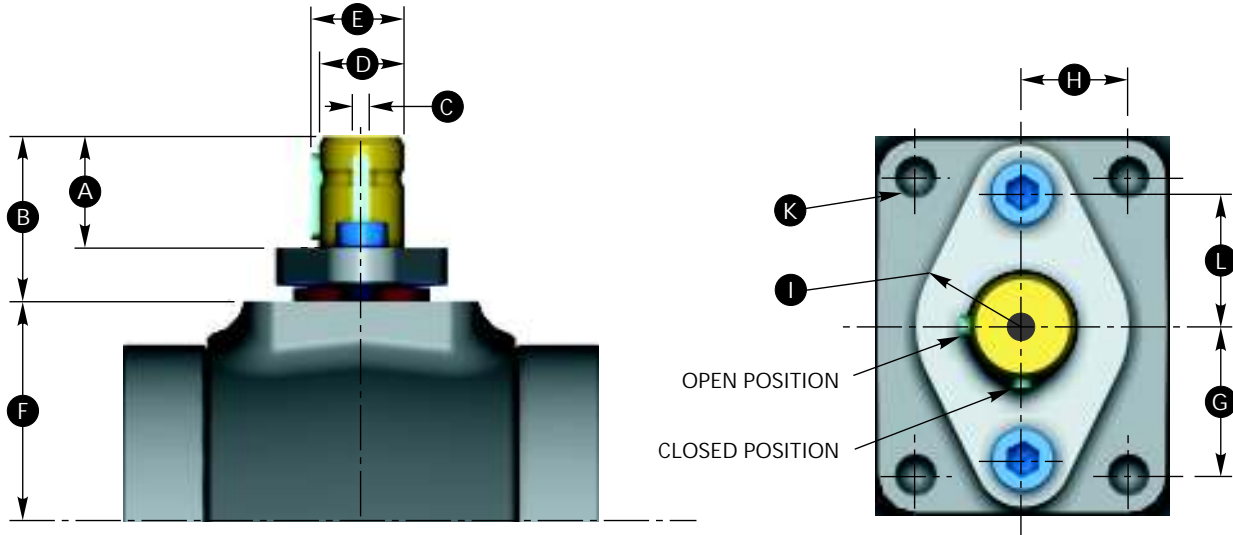

DIMENSIONS

SIZE in. (mm)	A	B	C	D	E	F	G	H	I	K	L
3 FP / 4 RP (80 FP / 100 RP)	1.64 (41.7)	2.395 (60.8)	0.25 (6.4)	1.248 (31.7)	1.362 (34.6)	4.875 (123.8)	1.75 (44.4)	1.25 (31.8)	1.25R (31.8R)	0.5-13UNC-2B x 0.62 DP. (12.7-13UNC-2B x 15.7 DP.)	1.566 (39.8)
(ASME 600-1500, WOG 2000-4000)											

4 in. (100 mm) FULL PORT
6 in. (150 mm) REDUCED PORT

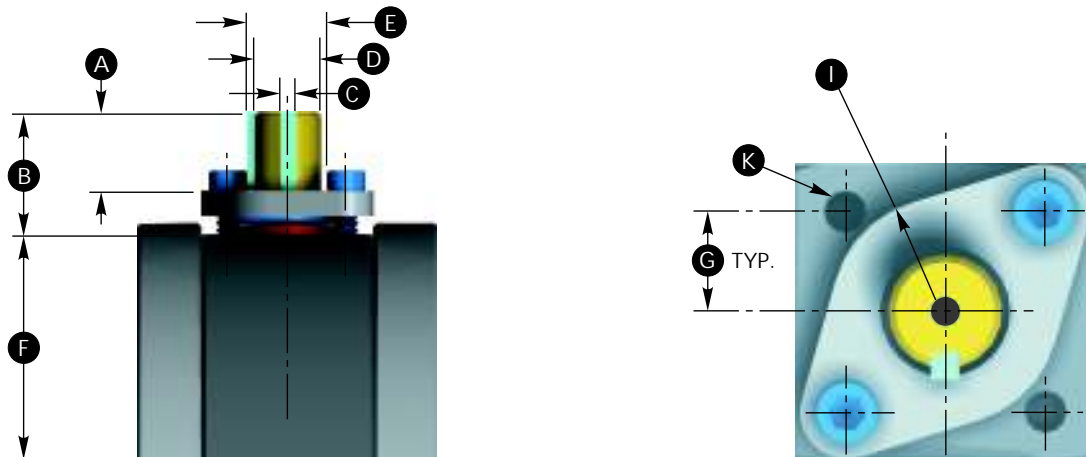

DIMENSIONS

SIZE in. (mm)	A	B	C	D	E	F	G	K	I
4 FP / 6 RP (100 FP / 150 RP)	1.255 (31.9)	1.85 (47.0)	0.25 (6.4)	1.00 (25.4)	1.11 (28.2)	4.688 (119.1)	0.877 (22.3)	0.375-24UNF-2B x 0.5 DEEP (9.5-24UNF-2B x 12.7 DEEP)	1.00 (25.4)
(ASME 150 / 300)									

* For B3 1 1/2 in., 2 in., 3 in. & 4 in. (40 mm, 50 mm, 80 mm & 100 mm) valves, see footnote on page 25.

FORGED STEEL FLOATING BALL VALVES MODEL T3 & B3 PRESSURE/TEMPERATURE RATINGS (SEATS AND SEALS)*

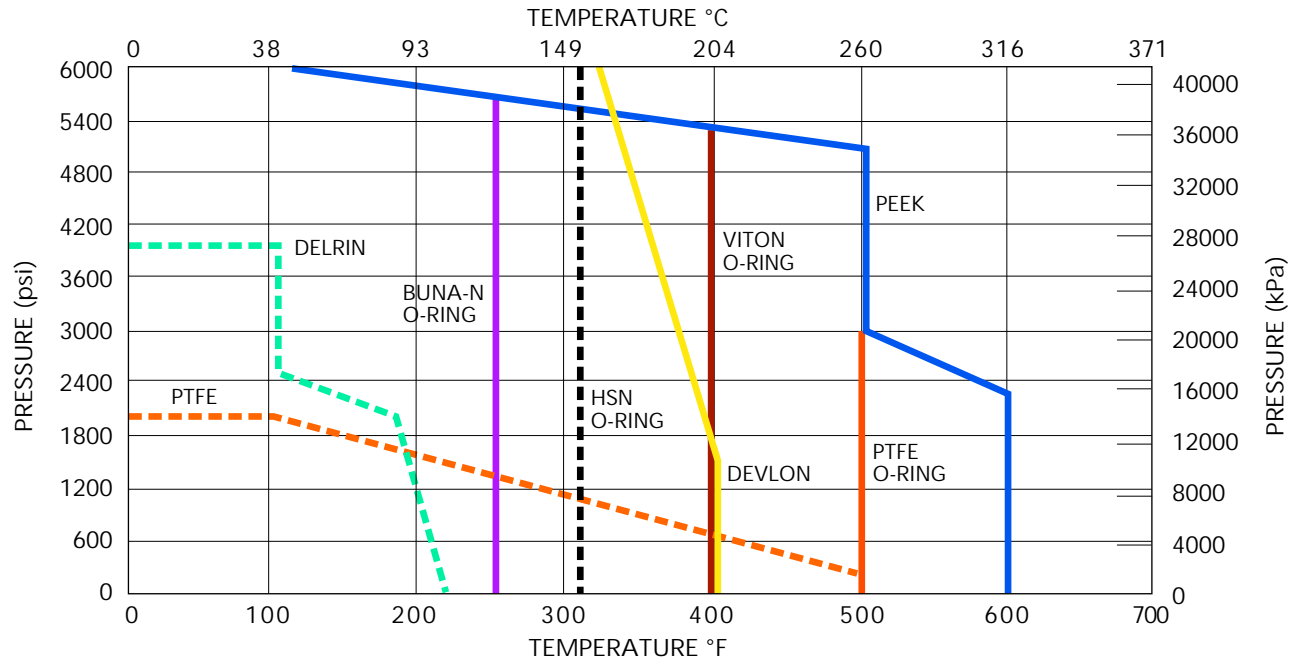

* Consult ASME B16.34 for Body and Adapter Material Pressure/Temperature Ratings.

MODEL T3 & B3 BREAKAWAY TORQUE DATA

Torque=inch-pounds

Bore Size in. (DN)	ASME CLASS (PN) Pressure (psi) Seat Material	150	300	600	900	1500	2500													
		(20)	(50)	(100)	(150)	(250)	(420)	0	285	740	1000	1480	2000	2220	3000	3705	4000	5000	6000	
1/2 (15)	Peek	72	84	96	108	120	132	144	156	180	192	216	240							
	Devlon	72	84	96	108	120	132	144	156	180	192	216	240							
	Delrin	60	72	84	96	108	120	132	144	168	180	-	-							
	Teflon	60	72	84	96	108	120	-	-	-	-	-	-							
7/8 (22)	Peek	276	276	276	276	276	300	324	360	420	444	540	660							
	Devlon	96	108	120	132	144	156	168	180	192	204	240	300							
	Delrin	96	108	120	132	144	156	168	180	192	204	-	-							
	Teflon	96	108	120	132	144	156	-	-	-	-	-	-							
1 1/2 (40)	Peek	600	648	696	744	792	840	864	936	1020	1080	1200	1500							
	Devlon	360	420	480	576	660	720	792	900	960	1020	1080	1260							
	Delrin	336	396	480	576	660	720	792	900	960	1020	-	-							
	Teflon	336	360	396	420	456	504	-	-	-	-	-	-							
2 (50)	Peek	840	1080	1440	1680	1920	2100	2280	2700	3120	3300	3600	4200							
	Devlon	600	720	900	1080	1200	1500	1680	1920	2160	2400	2400	2880							
	Delrin	600	720	900	1080	1320	1560	1740	2040	2280	2520	-	-							
	Teflon	600	636	816	936	1128	1344	-	-	-	-	-	-							
3 (80)	Peek	960	1440	2760	3840	4800	5760	6480	7200	8400	9000	-	-							
	Devlon	720	1200	1920	2400	2880	3360	3600	4080	4800	5760	-	-							
	Delrin	840	1380	2280	2640	3000	3600	3900	4200	4800	5760	-	-							
	Teflon	720	1320	1920	2400	2880	3600	-	-	-	-	-	-							
4 (100)	Peek	1440	2400	3840	-	-	-	-	-	-	-	-	-							
	Devlon	1200	2040	3120	-	-	-	-	-	-	-	-	-							
	Teflon	1080	1944	2820	-	-	-	-	-	-	-	-	-							

Torque values shown are to be used as a guide for actuator selection. All above torque values are based upon clean liquid service. Additional factors such as media characteristics, number of cycles and temperature may require an additional safety factor. Please contact the actuator supplier/manufacturer for these factors.

TRADEMARK INFORMATION

NUTRON® is a registered trademark which is owned by Cameron.

This document contains references to registered trademarks or product designations, which are not owned by Cameron.

Trademark	Owner
Devlon	Devol Engineering Limited
Impreglon	S.R. Metal Protection Ltd.
Inconel	INCO Nickel Sales, Inc.
Monel	INCO Alloys International, Inc.
Teflon	E.I. DuPont De Nemours & Company
Viton	E.I. DuPont De Nemours & Company

CAMERON, VALVES & MEASUREMENT TERMS AND CONDITIONS OF SALE

1. CONTRACT ACCEPTANCE:

Any written or oral purchase order received from Buyer by Seller shall be construed as a written acceptance of Seller's offer to sell and shall be filled in accordance with the terms and conditions of sale set forth herein. SELLER'S ACCEPTANCE OF THIS ORDER IS EXPRESSLY CONDITIONED ON BUYER'S ASSENT TO THE TERMS CONTAINED HEREIN. The terms and conditions of Seller's proposal (if any) and acknowledgement shall prevail over any conflicting or different terms in Buyer's order unless Buyer notifies Seller in writing of its objections thereto within fifteen (15) days from receipt of Seller's acknowledgement. Buyer's standard terms of purchase will not be considered a counteroffer to Seller's terms and conditions of sale. The failure of Seller to object to any provision in conflict herewith whether contained on Buyer's purchase order or otherwise shall not be construed as a waiver of the provisions hereof nor as an acceptance thereof.

2. QUOTATIONS AND PRICES:

Any product, service capability or manufacturing capability which may be available at the time a quotation is made is subject to prior sale. Prices quoted are subject to change without notice. The price in effect at the time of shipment including any escalation formula will apply, unless a valid quotation or written agreement to the contrary exists between Buyer and Seller. All prices shown are in U.S. dollars and are F.O.B. Seller's shipping point. Seller reserves the right to place a service charge on past due accounts at the highest rate permitted by law. Any documentation pertaining to traceability requirements for raw materials or products or documentation required for any routine or special processes must be identified by the Buyer at the time of quotation (if any) or at the time of order placement.

3. TAXES:

Any tax or other charge imposed by law on the sale or production of goods or the performance of services shall be paid by the Buyer, unless the law specifically provides that such payment must be made by Seller, in which case Buyer shall reimburse Seller for such payment as part of the purchase price. Custom duties, consular fees, insurance charges and other comparable charges will be borne by Buyer.

4. SHIPPING SCHEDULE AND DELIVERY:

Shipment schedules are given as accurately as conditions permit and every effort will be made to make shipments as scheduled. Seller will not be responsible for deviations in meeting shipping schedules nor for any losses or damages to Buyer (or any third party) occasioned by deviations in the shipping schedule, whether due to Acts of God, orders bearing priority ratings established pursuant to law, differences with workmen, local labor shortages, fire, flood, shortages or failure of raw materials, supplies, fuel, power or transportation, breakdown of equipment or any other causes beyond Seller's reasonable control, whether of similar or dissimilar nature than those enumerated. Seller shall have additional time within which to perform as may be reasonably necessary under the circumstances and shall have the right to apportion its production among its customers in such a manner as it may consider to be equitable. Seller reserves the right to furnish commercially equivalent or better substitutes for materials or to subcontract the Buyer's order or portions thereof as Seller deems necessary. In no event shall Seller be liable for any consequential damages resulting from failure or delay in shipment. If Buyer requires drawings, procedures, standards or similar material for approval, shipping schedules will be calculated from the time such approvals are received by Seller, since shipping schedules are based on Seller having all required information and a firm order from Buyer which is enterable into production. Any hold points, witness points or the need for inspection by Buyer's representatives must be identified by Buyer at the time of quotation (if any) and/or order placement in order that the effect on the prices or shipping schedules (if any) can be taken into account. Additional inspection or testing required by Buyer which affects normal production sequence will be considered as extending the shipping dates accordingly.

5. TERMS OF PAYMENT:

Terms of payment are 30 days from date of invoice unless otherwise stated in the quotation or Seller's order acknowledgment.

6. CANCELLATIONS AND RETURNS:

Purchase orders once placed by Buyer and accepted by Seller can be canceled only with Seller's written consent and upon terms which will save Seller from loss. No products may be returned for credit or adjustment without written permission from Seller's office authorized to issue such permission.

7. WARRANTIES:

All products of Seller's manufacture except for its Orbit product are warranted against defects of material and workmanship for a period of twelve (12) months from the date of installation or eighteen (18) months from date of shipment, whichever period first expires while its Orbit product is warranted for thirty six (36) months from date of shipment, when all such products are used in the service and within the pressure range for which they were manufactured. In the case of products or parts not wholly of Seller's manufacture, Seller's liability shall be limited to the extent of its recovery from the manufacturer of such products or parts under its liability to Seller. Any repair work performed by Seller is warranted for one year from completion of such repairs and applies only to work performed. If, within these specified periods, Seller receives notice from Buyer of any alleged defect in or nonconformance of any product or repair and if in the Seller's sole judgment the product or repair does not conform or is found to be defective in material or workmanship, then, Buyer shall, at Seller's request, return the part or product F.O.B. to Seller's designated plant or service location. Seller has no liability for removal or reinstallation of products or equipment. Seller, at its option and expense, shall repair or replace the defective part or product, or repay to Buyer the full price paid by Buyer for such defective part, repair or product. Any repayment of purchase price shall be without interest. Seller's warranty liability, including defects caused by Seller's negligence, shall be limited to such repair, replacement or refund, and shall not include claims for labor costs, expenses of Buyer resulting from such defects, recovery under general tort law or strict liability or for damages resulting from delays, loss of use, or other direct, indirect, incidental or consequential damages of any kind. Seller will not be responsible for failures of products which have been in any way tampered with or altered by anyone other than an authorized representative of Seller, failures due to lack of compliance with recommended maintenance procedures or products which have been repaired or altered in such a way (in Seller's judgment) as to affect the products adversely. THIS WARRANTY IS EXPRESSLY IN LIEU OF ALL OTHER WARRANTIES, EXPRESS, STATUTORY OR IMPLIED, INCLUDING THE WARRANTY OF MERCHANTABILITY AND FITNESS FOR PARTICULAR PURPOSE WHICH EXCEED THE FOREGOING WARRANTY.

8. ENGINEERING AND SERVICE:

Upon request, Seller will provide engineering and/or technical information regarding its products and their uses and, if feasible, will provide personnel to assist Buyer in effecting field installations and/or field service. Any such information, service or assistance so provided, whether with or without charge, shall be advisory only.

9. LABOR STANDARDS:

Seller hereby certifies that these products were produced in accordance with all applicable requirements of Section 6, 7 and 12 of the Fair Labor Standards Act as amended and of regulations and orders of the United States Department of Labor issued under Section 14 thereof.

10. INSPECTION:

Unless otherwise agreed in writing, final inspection and acceptance of products must be made at Seller's plant or other shipping or receiving point designated by Seller and shall be conclusive except as regards latent defects. Buyer's representatives may inspect at the Seller's plant or shipping point during working hours prior to shipment in such manner as will not interfere with operations.

11. DELIVERY AND ACCEPTANCE:

Delivery shall be in accordance with the requirements in the Purchase Contract, provided, in the event Buyer is unable to accept delivery upon completion of the manufacture of the Goods in accordance with such requirements, Buyer agrees that (i) title and risk of ownership shall pass to Buyer on date of Seller's invoice, and (ii) Buyer will make payments within thirty days after date of such invoice. Seller shall retain custodial risk of loss until delivery is made in accordance with such requirements.

12. EXPORT COMPLIANCE:

The Buyer shall provide the Seller with relevant end-use, end-user and country of end-use information with respect to the goods, services, software or technology to be supplied hereunder (collectively, "Items"). Based on and in reliance on such information, the Seller will supply such Items in compliance with applicable trade and customs laws including that of the United States of America. The Seller cautions and the Buyer acknowledges that any change in end-use, end-user or country of end-use (including a shipment between countries other than the U.S.) may be restricted or prohibited by applicable trade and

customs law, whether it be of the U.S. or other country. The Parties shall comply with all trade and customs laws (including U.S. Export Controls) except for any such laws which conflict with or are otherwise penalized under the laws of the U.S., which in the event of such conflict, Seller shall notify Buyer. The Buyer agrees in particular that it shall not use and shall not permit any third party to use such items in connection with the design, production, use, or storage of chemical, biological or nuclear weapons or missiles of any kind.

13. TRANSPORTATION CHARGES, ALLOWANCES, CLAIMS:

All prices are F.O.B. Seller's plant or other designated shipping point. No freight is allowed unless stated in Seller's quotation (if any) or in a written contract which may exist between Seller and Buyer at the time of shipment. If Seller's quotation or a written contract states that all or a portion of freight is allowed, all prices are F.O.B. Seller's plant or other designated shipping point, with most economical surface transportation allowed. If the quoted or contractual price includes transportation, Seller reserves the right to designate the common carrier and to ship in the manner it deems most economical. Added costs due to special routing requested by the Buyer are chargeable to the Buyer. Under no circumstances is any freight allowance which is absorbed by Seller to be deducted from the selling price. If the quoted price or contract includes transportation, no deduction will be made in lieu thereof whether Buyer accepts shipment at plant, warehouse, freight station, or otherwise supplies its own transportation. When sales are made from the Seller's warehouse, Seller reserves the right to charge either actual or pro-rated freight from Seller's principle point of manufacture to Seller's warehouse. Buyer assumes risk of loss upon delivery to the carrier, regardless of who pays shipping costs. Seller endeavors to pack or prepare all shipments so that they will not break, rust or deteriorate in transit, but does not guarantee against such damage. Unless requested in writing by the Buyer, no shipments are insured by Seller against damage or loss in transit. Seller will place insurance as nearly as possible in accordance with Buyer's written instructions but in such case Seller acts only as agent between the insurance company and the Buyer and assumes no liability whatsoever. Any claims for shipping loss, breakage or damage (obvious or concealed) are Buyer's responsibility and should be made to the carrier. All claims regarding shortages must be made within thirty (30) days from receipt of shipment and must be accompanied by the packing list(s) covering the shipment.

14. INDEMNIFICATION AND LIMITATION OF LIABILITY:

A. INDEMNIFICATION:

"Buyer Group" means: Buyer, its parent (if any), subsidiaries, affiliates, co-owners, co-venturers, partners and any entity with whom Buyer has an economic interest with respect to the Work including Buyer's customer and its and their respective employees, personnel, directors, officers, borrowed servants, representatives, agents, contractors and subcontractors (respectively and of any tier or level and who are not included within the Seller Group), "Seller Group" means: Seller, its parent (if any), subsidiaries, affiliates, co-owners and its and their respective employees, personnel, directors, officers, borrowed servants, representatives, agents, contractors and subcontractors (respectively and of any tier or level and who are not included within the Buyer Group), "Negligence" means: sole, joint or concurrent, active, passive, gross or willful misconduct.

(1) Seller shall release, defend, save, indemnify (collectively "Indemnify") and hold Buyer Group harmless from and against all claims, demands, losses, damages and causes of action of whatever kind or nature (collectively "Claims"), for loss of or damage to the property of the members of the Seller Group even if such Claims arise from or attributable to the Negligence of the members of Buyer Group.

(2) Seller shall Indemnify and hold Buyer Group harmless from and against all Claims for the death(s) of or personal injury(ies) to members of the Seller Group even if such Claims arise from or attributable to the Negligence of the members of Buyer Group.

(3) Buyer shall Indemnify and hold Seller Group harmless from and against all Claims for loss of or damage to the property (including the Work) of the members of the Buyer Group even if such Claims arise from or attributable to the Negligence of the members of Seller Group.

(4) Buyer shall Indemnify and hold Seller Group harmless from and against all Claims for the death(s) of or personal injury(ies) to members of the Buyer Group even if such Claims arise from or attributable to the Negligence of the members of Seller Group.

(5) Buyer (on its own behalf and on behalf of Buyer Group) and Seller (on its own behalf and on behalf of Seller Group) shall Indemnify and hold each other harmless from and against any and all Claims asserted against them by or on behalf of any third party for the death(s) of or personal injury (ies) to such a third party, as well as loss (es) of or damage(s) to the property of such a third party. A third party is a person or entity not included in Buyer Group or Seller Group. It is agreed by Buyer and Seller that their respective duty of indemnity to each other with respect to Claims asserted against them by a third party pursuant to this Article 14 (A) (5) shall be limited to their respective degree of Negligence.

(6) Notwithstanding any other provision contained in this Agreement, Buyer shall Indemnify and hold the members of Seller Group harmless from and against all Claims (including clean-up costs and loss (es) of oil, gas or hydrocarbons) arising from pollution, contamination, dumping or spilling of any substance and even if arising out of or attributable to the Negligence of the members of the Seller Group.

B. INDEMNITY FOR CONSEQUENTIAL DAMAGES:

UNDER NO CIRCUMSTANCES SHALL SELLER BE LIABLE FOR ANY SPECIAL, CONSEQUENTIAL, INCIDENTAL, EXEMPLARY OR PUNITIVE DAMAGES (collectively "CONSEQUENTIAL"). AS DEFINED BY THE LAWS GOVERNING THIS PURCHASE ORDER, NOR FOR ANY LOSS OF ANTICIPATED PROFITS, LOSS OF BUSINESS OPPORTUNITY, LOSS OF USE OF EQUIPMENT OR OF ANY INSTALLATION, SYSTEM OR FACILITY INTO WHICH SELLER'S EQUIPMENT MAY BE LOCATED OR AT WHICH MEMBERS OF THE SELLER GROUP MAY BE PERFORMING WORK AND BUYER AGREES TO "INDEMNIFY" AND HOLD SELLER GROUP HARMLESS FROM AND AGAINST ANY "CLAIMS" FOR SUCH "CONSEQUENTIAL" DAMAGES EVEN IF ARISING OUT OF OR ATTRIBUTABLE TO THE "NEGLIGENCE" OF THE MEMBERS OF THE SELLER GROUP.

C. LIMITATION OF LIABILITY:

EXCEPT AS OTHERWISE EXPRESSLY LIMITED IN THIS AGREEMENT IT IS THE EXPRESS INTENTION OF THE PARTIES HERETO THAT ALL INDEMNITY OBLIGATIONS AND/OR LIABILITIES HEREBY ASSUMED BY THE PARTIES SHALL BE: (i) SUPPORTED BY INSURANCE; (ii) WITHOUT LIMIT; (iii) AND WITHOUT REGARD TO THE CAUSE OR CAUSES THEREOF, INCLUDING, BUT NOT LIMITED TO, PREEXISTING CONDITIONS (WHETHER SUCH CONDITIONS BE PATENT OR LATENT); THE UNSEAWORTHINESS OF ANY VESSEL OR VESSELS (WHETHER OR NOT PREEXISTING); THE UNAIRWORTHINESS OF ANY AIRCRAFT; BREACH OF REPRESENTATION OR WARRANTY (EXPRESS OR IMPLIED); BREACH OF CONTRACT; BREACH OF DUTY (STATUTORY, CONTRACTUAL, COMMON LAW OR OTHERWISE); STRICT LIABILITY; CONDITION OF RUIN OR DEFECTIVE PREMISES, EQUIPMENT, FACILITIES, OR APPURTENANCES OF ANY PARTY UNDER ANY CODE, LAW OR (WHETHER OR NOT SAID CONDITION IS PREEXISTING AND/OR LATENT, PATENT OR OTHERWISE); THE LOADING OR UNLOADING OF PERSONS OR CARGO; TORT; OR THE NEGLIGENCE OR FAULT OF ANY PARTY (AS DEFINED AT THE BEGINNING OF THIS ARTICLE 14; OR ANY OTHER THEORY OF LEGAL LIABILITY).

Seller's total responsibility for any claims, damages, losses or liability arising out of or related to its performance of this contract or the products or services covered hereunder shall not exceed the purchase price.

15. MODIFICATION, RESCISSION & WAIVER:

The terms herein may not be modified or rescinded nor any of its provisions waived unless such modification, rescission or waiver is in writing and signed by an authorized employee of Seller at its office in Houston, Texas. Failure of Seller to insist in any one or more instances upon the performance of any of the terms and conditions of the contract or the failure of Seller to exercise any of its rights hereunder shall not be construed as a waiver or relinquishment of any such term, condition, or right hereunder and shall not affect Seller's right to insist upon strict performance and compliance with regard to any unexecuted portions of this contract or future performance of these terms and conditions.

All orders must be accepted by an authorized employee of Seller. The rights and duties of the parties and construction and effect of all provisions hereof shall be governed by and construed according to the internal laws of the State of Texas. Any disputes which arise under this agreement shall be venued in the District Court of Harris County, Texas or in the Southern District of Texas.

**VALVES & MEASUREMENT**

3250 Briarpark Drive, Suite 300
Houston, Texas 77042
USA Toll Free 800 323 9160

For the most current contact and location information go to: www.c-a-m.com